

Khulna University of Engineering & Technology

Department of Mechanical Engineering

B. Sc. Engineering 4th Year 1st Term Examination, 2024

ME 4105

(Applied Thermodynamics)

Time: 3 Hours

Full Marks: 210

N.B.: i) Answer any THREE questions from each section in separate scripts.

ii) Figures in the right margin indicate full marks.

iii) Assume reasonable data if any missing.

SECTION-A

- 1(a) Why are regenerators, reheaters and intercoolers used in gas turbine? Explain. 07
- 1(b) Briefly explain the techniques used for cooling the gas turbine blades and combustor in a gas turbine plant. 06
- 1(c) Show that the efficiency of an ideal gas turbine cycle with heat exchanger depends on both maximum cycle temperature and pressure ratio. 08
- 1(d) The following description pertains to a certain gas turbine unit: inlet conditions to compressor = 1 bar and 310K; $\eta_c = 80\%$; pressure ratio = 4; turbine inlet temperature = 820K; $\eta_T = 85\%$; heating value of fuel used = 44 MJ/kg for an airflow rate of 80 kg/min, determine – (i) air fuel ratio of the turbine plant, (ii) net horsepower of the installation, (iii) overall efficiency of the plant, and (iv) back work ratio. Assume, $c_p = 1.005$ kJ/kg.K and $\gamma = 1.4$ both for air and gases. 14
- 2(a) What are the essential differences between turbo-prop and turbo-fan engines? With neat sketch, describe the working principle of turbo-jet engine. 12
- 2(b) Show that the efficiency of rocket propulsion can be expressed as $\eta_{\text{rocket}} = 2\sigma/(1 + \sigma^2)$ where the symbols have their usual meanings. 10
- 2(c) In a jet propulsion unit, air at 1 bar and 3°C is compressed in an uncooled compressor to a pressure of 3.5 bar where $\eta_c = 82\%$. The air is then led to combustion chamber where fuel is burnt and products of combustion at 500°C pass through a turbine with $\eta_c = 84\%$. The exhaust gases from the turbine are further expanded in a nozzle down to 0.8 bar, the nozzle efficiency being 90%. Calculate – (i) power required to run the compressor, (ii) air fuel ratio, the fuel used has a heating value of 38 MJ/kg and heater loss is 10% of heating value, (iii) pressure of gases leaving the turbine. Take the initial velocity of aircraft as 200 m/s, $c_p = 1.005$ kJ/kg.K and $\gamma = 1.4$ both for air and gases. 13
- 3(a) What are differences between velocity-compounding and pressure compounding steam turbine? Show that for frictionless and symmetric blading impulse turbine, the gross stage efficiency, $\eta_{gs} = \eta_b \cdot \eta_n$, where η_b is the blading efficiency and η_n is the nozzle efficiency. 18
- 3(b) Steam issues from the nozzle of a de Laval turbine with a velocity of 910 m/sec. The nozzle angle is 25°. The mean diameter of the blade is 23 cm and speed of rotation 21000 rpm. The mass flow through the turbine nozzles and blading is 0.3 kg of steam per second. If the friction loss in the blade chamber is 32% of the kinetic energy corresponding to the relative velocity at inlet to the blades, draw the velocity diagram and calculate the following:
(i) Velocity of whirl, (ii) Tangential and axial forces on blades, (iii) Workdone on blades per second, (iv) Horse-power of wheel, and (v) Blade efficiency. 17
- 4(a) Discuss the development process of profile blade from plate blade sections. Describe a profile blade with neat sketch. 10
- 4(b) What is meant by Re-heat factor? Show the condition curves in h-s diagram for a multi-stage turbine and explain its effects on turbine efficiency. 08
- 4(c) What are the losses encountered in steam turbines? Explain. How is blade windage accounted? 07
- 4(d) What is degree of reaction? Show that in Parson's turbine the degree of reaction is half. 10

SECTION-B

- 5(a) What is the physical significance of volumetric efficiency? How inlet valve timing and engine speed affect volumetric efficiency? 06
- 5(b) Explain “lean mixture” and “rich mixture”. “Diesel engines generally operate with overall lean mixture” – Justify the statement. 07
- 5(c) “Pumping work is minimum in DISI engine, and positive in turbocharged engine” – Explain with necessary diagrams 06
- 5(d) A test on a single cylinder 4-stroke engine with a cylinder diameter of 18 cm and stroke of 28 cm yielded the following: 16
Speed = 400 rpm, diameter of the brake = 1.52 m, net load on the brake = 1050 N, mep = 7.2 bar, fuel consumption = 3.5 kg/hr, barometer reading = 750 mm Hg, room temperature = 20°C, heating value of fuel = 44 MJ/kg, air-fuel ratio by mass = 25, flow of jacket cooling water = 4.5 kg/min, rise in temperature of cooling water = 38°C, exhaust gas temperature = 210°C.
Determine – (i) indicated and brake thermal efficiency, (ii) volumetric efficiency, and (iii) draw up a heat balance sheet.
- 6(a) Discuss the three mixture formation strategies commonly employed for SI engines. 08
- 6(b) “Factors tending to increase knock in SI engines, tend to reduce knock in CI engines” – Justify the validity of this statement. 08
- 6(c) How ignition delay in CI engine differs from that in SI engine? Describe the different stages of combustion in CI engine with the help of heat release rate – crank angle diagram. 14
- 6(d) What are the causes of surface ignition? Explain. 05
- 7(a) State the importance of “scavenging”. “Two-stroke CI engine is more common than two-stroke SI engine” – Explain. 07
- 7(b) What are the factors that limit the degree of supercharging in SI and CI engines? What are the modifications required in engines if supercharging is to be employed? Explain. 11
- 7(c) Compare and contrast open combustion chamber with divided combustion chamber. Why can low ignition quality fuel be used in very large, slow speed CI engines? Explain. 08
- 7(d) What are meant by ‘swirl’ and ‘tumble’ in relation to engines? How do squish influences the combustion in SI engine? 09
- 8(a) Why is electronic fuel injection (EFI) superior over conventional carburation? Describe different types of fuel injection system for CI engines. 12
- 8(b) How does the chemical structure of fuel determine the ignition quality? Explain fractional distillation, and conversion processes in brief. 11
- 8(c) Explain the following terms: 12
(i) RON, (ii) CN, (iii) Crevice flow, (iv) Blow-by

– – END – –

Khulna University of Engineering & Technology

Department of Mechanical Engineering

B. Sc. Engineering 4th Year 1st Term Examination, 2024

ME 4113
(Fluid Machinery)

Time: 3 Hours

Full Marks: 210

- N.B.:** i) Answer any *THREE* questions from each section in separate scripts.
ii) Figures in the right margin indicate full marks.
iii) Assume reasonable data if any missing.

SECTION-A

- 1(a) Explain the working principle of double acting reciprocating pump with necessary discharge vs crank angle graph. 07
- 1(b) How does an air vessel maintain uniform flow velocity during suction stroke? Determine the crank angle position for which there will be no flow from or into the air vessel for a single acting reciprocating pump. 10
- 1(c) A single acting reciprocating pump has a plunger of 80 mm diameter and stroke length of 150 mm. It takes its supply of water from a sump 3 m below the pump through a pipe 4.5 m long and 30 mm diameter. It delivers water to a tank 12 m above the pump through a pipe 25 mm in diameter and 15 m long. 18
- If separation occurs at 78.48 kN/m^2 below atmospheric pressure, find the maximum speed at which the pump may be operated without separation, assume the plunger to have simple harmonic motion.
- 2(a) What is (i) specific speed of centrifugal pump, (ii) net positive suction head (NPSH), and (iii) manometric efficiency. 06
- 2(b) With appropriate sketch, describe the working of a volute pump with vortex or whirlpool chamber. 10
- 2(c) Deduce the expression for the limiting value of suction lift. 09
- 2(d) A centrifugal pump lifts water against a static head of 40 m, of which 4 m is suction lift. The suction and delivery pipes are both 150 mm in diameter, the head loss in the suction pipe is 2.3 m and in the delivery pipe, 7.4 m. The impeller is 420 mm in diameter and 25 mm width at the mouth; it revolves at 1200 rpm and its effective vane angle at exit is 35° . If $\eta_{\text{mano}} = 82\%$ and $\eta_o = 72\%$, determine the power required to drive the pump. 10
- 3(a) Discuss the main difference between impulse and reaction turbine. Write short notes on the following terms of a turbine: (i) speed ratio, (ii) jet ratio, (iii) specific speed. 09
- 3(b) Classify the hydraulic turbines based on: 08
- (i) direction of flow of water in the runner,
(ii) head and quantity of water required.
- 3(c) An inward flow turbine (reaction type with radial discharge) with an overall efficiency of 80% is required to develop 150 kW. The head is 8 m; peripheral velocity of the wheel is $0.96\sqrt{2gH}$; the radial velocity of the flow is $0.36\sqrt{2gH}$. The wheel is to make 150 rpm, and the hydraulic losses in the turbine are 22% of the available energy. Determine – 18
- (i) the angle of the guide blade at inlet,
(ii) the wheel vane angle at inlet,
(iii) the diameter of the wheel,
(iv) the width of the wheel at inlet.
- 4(a) State the Euler turbine equation. Deduce the expression for determining the degree of reaction of a reaction turbine. 12
- 4(b) The draft tube of a Francis turbine permits a negative head to be established at the outlet of the turbine runner. Justify this statement. 08

- 4(c) A jet of water having a velocity of 30 m/s strikes a series of radial curved vanes mounted on a wheel which is rotating at 200 rpm. The jet makes an angle of 20° with the tangent to the wheel at inlet and leaves the wheel with a velocity of 5 m/s at an angle of 130° to the tangent to the wheel at outlet. Water is flowing from outward in a radial direction. The outer and inner radius of the wheel are 0.5 m and 0.25 m, respectively. Determine – (i) vane angles at inlet and outlet, (ii) work done per unit weight of water, and (iii) efficiency of the wheel. 15

SECTION-B

- 5(a) Show that curl of velocity is equal to the vorticity in a flow field. Explain the relationship between vorticity and circulation. 10
- 5(b) What is velocity potential? Show that inviscid, incompressible and irrotational flow fields are governed by Laplace's equation of velocity potential. 07
- 5(c) Deduce the expression of Cauchy-Reiman equation in cylindrical polar coordinate. 08
- 5(d) A velocity potential function for 2-D flow is given by $\phi = y^2 - x^2 + Axy$. Compute the value of the constant A when the discharge between the streamlines passing through points (1,3) and (1,6) is 21 units. 10
- 6(a) How Rankine Oval can be created using potential flow concept? Derive the expressions for length and width of the Rankine Oval. 17
- 6(b) Deduce the expression of stream function, ψ of a doublet flow. 12
- 6(c) Consider water at 20°C flowing at 6 m/s past a 1 m diameter circular cylinder. What doublet strength is required to simulate this flow? If the freestream pressure is 200 kPa, use inviscid theory to estimate the surface pressure at (i) 135° , and (ii) 90° . 08
- 7(a) Derive the expression for surface wave speed and hence Froude number for open channel flow. 11
- 7(b) What is critical depth? Show that specific energy is minimum at critical condition for a channel of general cross-section. Express minimum specific energy in terms of critical depth. 12
- 7(c) An asphalt-lined trapezoidal channel as shown carries $10 \text{ m}^3/\text{s}$ of water under uniform flow conditions when $S_0 = 0.0015$. What is the normal depth? Assume Manning's coefficient, $n = 0.016$. 12

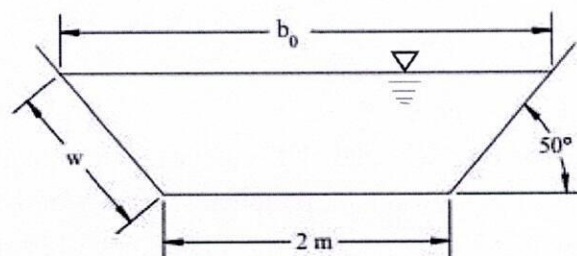

- 8(a) What is meant by hydraulic jump? Show that the head loss in a hydraulic jump formed in a rectangular channel may be expressed as: 17

$$\Delta E = \frac{(y_2 - y_1)^3}{4y_1y_2} \quad \text{where the symbols have their usual meaning.}$$

- 8(b) A rectangular channel carries a discharge of $2.2 \text{ m}^3/\text{sec}$ per meter of width. A hydraulic jump occurs and if the loss due to jump is 2.9 m, determine the conjugate depths. 18

-- END --

Khulna University of Engineering & Technology

Department of Mechanical Engineering

B. Sc. Engineering 4th Year 1st Term Examination, 2024

ME 4015

(Automobile Engineering)

Time: 3 Hours

Full Marks: 210

N.B.: i) Answer any THREE questions from each section in separate scripts.

ii) Figures in the right margin indicate full marks.

iii) Assume reasonable data if any missing.

SECTION-A

- 1(a) Outline the major components of an automobile and explain the functions of them. 08
- 1(b) How to identify drive wheels in an automobile? Explain with necessary figures. Classify the types of automobiles commonly used in Bangladesh. 08
- 1(c) Write short notes on: 09
(i) Cylinder block, (ii) Piston and piston ring, and (iii) Crank shaft.
- 1(d) Why timing belt and chain tensioner are used in engine? Explain the cooling of exhaust valve. 10
- 2(a) What is octane rating of a SI engine? Show the power vs air-fuel ratio curve with explanation. 09
- 2(b) Why float is used in a carburetor? Explain its operating principle. 10
- 2(c) Explain the operating mechanism of a gasoline fuel injection system, including an appropriate diagram. 08
- 2(d) Describe the working principle of EFI. Write short notes on: 08
(i) Throttle position sensor, (ii) Atmospheric pressure and air temperature sensors.
- 3(a) Differentiate between supercharger and turbo-charger with necessary diagrams. Why intercooler is used in turbochargers? 08
- 3(b) What are the various circuits of a carburetor? Explain the working of accelerator pump circuit of a carburetor with neat sketch. 10
- 3(c) List common carburetor problems and describe the measures that can be taken to avoid them. How often should we change the lubricating oil used in engine? 07
- 3(d) Briefly explain water cooling system of IC engine. What are the functions of antifreeze. 10
- 4(a) What are the functions of electrical system in an automobile? Draw a schematic diagram of automobile electrical system. 08
- 4(b) Show the charging and discharging conditions of lead acid battery with figures. Describe the troubles faced in battery used in automobile. 10
- 4(c) State the objectives of an ignition system and briefly describe the roles of the components in a contact point ignition system. 10
- 4(d) Identify the various types of electronic ignition systems and mention the advantages of using a distributorless ignition system. 07

SECTION-B

- 5(a) Why clutch system is used in vehicle? Describe the working principle of a diaphragm spring clutch with neat sketch. 15
- 5(b) Is there any grooves that are cut in the friction disc? Why? Mention the purpose of torsional spring in a clutch. 10
- 5(c) Draw and explain the functions of slip joint, universal joint and CV joint in automobile power transmission system. 10
-
- 6(a) Why is synchronization necessary for shifting gears? Describe how it works? 07
- 6(b) Draw the power transmission in reverse gear for four speed transmission with all forward speed gears in constant mesh. 10
- 6(c) Why is power brake used? Describe the working principle of a power brake. 08
- 6(d) Why is master cylinder used in automobiles? Describe the working principle of hydraulic brake system used in automobiles. 10
-
- 7(a) Why is differential gear box used? Describe the working principle of differential gear box with neat sketch. 11
- 7(b) What is meant by front wheel geometry of a car? Explain the different front wheel geometries of a car. 09
- 7(c) Why springs are used in the suspension system? Describe the working principle of a gas filled shock absorber with neat sketch. 08
- 7(d) What is muffler? Show that the construction of a muffler with a diagram and label it properly. 07
-
- 8(a) What is catalytic converter? How does it work in the car exhaust system? 09
- 8(b) Discuss the merits and demerits of radial tyre over a bias ply tyre. 08
- 8(c) Mention the merits and demerits of a disc brake over drum brake. 08
- 8(d) What are meant by IC engine pollution and emission? Describe any pollution control system. 10

-- END --

Khulna University of Engineering & Technology

Department of Mechanical Engineering

B. Sc. Engineering 4th Year 1st Term Examination, 2024

ME 4019
(Aerodynamics)

Time: 3 Hours

Full Marks: 210

- N.B.: i) Answer any THREE questions from each section in separate scripts.
ii) Figures in the right margin indicate full marks.
iii) Assume reasonable data if any missing.

SECTION-A

- 1(a) What is vortex sheet? Show that the local tangential velocity jump across the vortex sheet is equal to the local sheet strength. 10
- 1(b) Discuss the Kutta condition with neat sketches. Also, show that circulation is zero at the trailing edge. 10
- 1(c) What is aerodynamic center and center of pressure for an airfoil? Show that both are at the quarter-chord point for symmetric airfoil. Suppose the solution of thin-airfoil theory is known as 15

$$k = 2U\alpha \frac{1 + \cos \theta}{\sin \theta} \quad \text{symbols have their usual meanings.}$$

- 2(a) Find the solution of the fundamental equation of general thin-airfoil theory for cambered airfoil. Suppose the camber line is expressed by the equation below- 15

$$\frac{dy_c}{dx} = A_0 + \sum_{n=1}^{\infty} A_n \cos n\theta$$

- 2(b) The equation of mean camber line for NACA 2412 airfoil is 20

$$y_c = \begin{cases} 0.125(0.8x - x^2), & \text{for } 0 \leq x < 0.4 \\ 0.0555(0.2 + 0.8x - x^2), & \text{for } 0.4 \leq x \leq 1 \end{cases}$$

Determine the section lift coefficient, section moment coefficient, center of pressure and zero-lift angle of attack.

- 3(a) Why is the induced drag being an integral part for lifting finite wings? Explain with necessary sketches. What are the consequences of downwash? 10
- 3(b) Derive the relationship between the lift-curve slope for a finite wing with that of an infinite wing. 10
- 3(c) A light airplane has a wing area of 16 m² and wingspan of 10 m. Its maximum gross weight is 1120 kg. The wing uses an NACA 65-415 airfoil, which has a lift slope of 0.1033 per degree and $\alpha_{L=0} = -3^\circ$. Assume $\tau = 0.12$. If the airplane is cruising at 200 km/hr at standard sea-level at its maximum gross-weight. For steady level flight (weight equals lift), calculate the geometric angle of attack of the wing. 15

- 4(a) For the general arbitrary distribution of lift along the span of a finite wing, derive expression for the downwash distribution along the span, and the induced drag coefficient. Start your derivation with the following expression and take $C_L = \pi(AR)A_1$ 17

$$w(y_0) = -\frac{1}{4\pi} \int_{-b/2}^{+b/2} \left(\frac{d\Gamma}{dy} \right) \frac{dy}{y_0 - y} \quad \text{symbols have usual meanings.}$$

- 4(b) The spanwise distribution of circulation along the span of an untwisted rectangular wing of aspect ratio 6 and span of 12 m, can be written in the form below: 18

$$\Gamma(\theta) = 2bV_\infty(0.0234 \sin \theta + 0.00268 \sin 3\theta + 0.00072 \sin 5\theta + 0.00010 \sin 7\theta)$$

Determine the circulation distribution at the mid-span position, $\theta = \pi/2$. If the airplane is travelling at 90 m/s velocity, calculate lift and induced drag coefficient. Assume $\rho_\infty = 1.225 \text{ kg/m}^3$.

SECTION-B

- 5(a) Show the basic structural components of a modern aircraft and explain them with neat sketch. 10
- 5(b) Explain airfoil nomenclature with neat sketch. Also, describe NACA 0014, NACA 2415, and NACA 23012. 15
- 5(c) In a low-speed, incompressible flow, the following experimental data are obtained for a NACA 4412 airfoil section at an angle of 4° , $c_l = 0.85$, and $c_{m,c/4} = -0.085$. calculate the location of center of pressure. 10

- 6(a) What is compressibility? When should the aerodynamic analysis include the compressibility? 08
- 6(b) Show that the linearized velocity potential equation as 15

$$(1 - M_\infty^2) \frac{\partial^2 \hat{\phi}}{\partial x^2} + \frac{\partial^2 \hat{\phi}}{\partial y^2} = 0$$

- 6(c) For an airfoil, the low-speed incompressible wind tunnel test data is given by 12

$$(t/c)' = 0.05; \alpha' = 4^\circ; c_l' = 0.8$$

Determine the lift coefficient of the airfoil at $M_\infty = 0.6$. What should be the thickness-to-chord ratio (t/c) and the angle of attack (α) for compressible flow.

- 7(a) Why should subsonic airfoils not be used in supersonic flight? Explain with sketch. 06
- 7(b) Show that the lift coefficient for an arbitrary shaped supersonic airfoil depends only on the angle of attack. 17
- 7(c) Prove that for small perturbation, the pressure coefficient is $C_p = \frac{-2\hat{u}}{V_\infty}$, where \hat{u} is the perturbation velocity and V_∞ is the free stream velocity. 12

- 8(a) Describe the following terms: (i) Critical Mach number, and (ii) Area rule. 08
- 8(b) What is viscous interaction phenomenon? How does it affect the inviscid flow? 08
- 8(c) At hypersonic speeds, how do the lift coefficient C_L and drag coefficient C_D for a wing vary with angle of attack α . 09
- 8(d) Derive sine square formula for hypersonic flows. 10

-- END --

Khulna University of Engineering & Technology

Department of Mechanical Engineering

B. Sc. Engineering 4th Year 1st Term Examination, 2024

ME 4083
(Robotics)

Time: 3 Hours

Full Marks: 210

- N.B.: i) Answer any THREE questions from each section in separate scripts.
ii) Figures in the right margin indicate full marks.
iii) Assume reasonable data if any missing.

SECTION-A

- 1(a) "Robotic automation is considered as the future of modern manufacturing" – Justify the statement. 10
- 1(b) Briefly explain the application of AI and machine learning in robotics. 12
- 1(c) Describe the historical evolution of robot. Discuss the laws of robotics proposed by Asimov. 13
- 2(a) What are the significance of frame-to-frame transformation in robotics? 11
Suppose frame {B} is rotated relative to frame {A} about \hat{X} by 120° , translated 37 cm in \hat{Y}_A and 59 cm in \hat{Z}_A . Draw the frames and find A_p , where $B_p = [0 \ 31 \ 27]^T$ cm.
- 2(b) Draw the following robots and mention their DOF. 09
(i) Cartesian robot.
(ii) SCARA robot.
(iii) Polar robot.
- 2(c) Derive the homogeneous transformation matrix between two links by using the D-H parameters. 15
- 3(a) Draw a 3 DOF manipulator with one-revolute joint and two-prismatic joints, considering the robot is hanging from a side wall. Draw the frames on it, find the D-H parameters and find the relationship between the base and end effector. (Choose suitable link length and joint angles) 15
- 3(b) Explain the case of no solution and multiple solution for inverse kinematics problems. 05
- 3(c) What are the approaches that can be used to solve inverse kinematics problem? Find the joint angles of a 2-link planer manipulation from a given end-effector position (x, y) . 15
- 4(a) A two-link manipulator with rotational joints is shown in figure. Derive the velocity equation of the tip of the arm as a function of joint rates. Give the answer in two forms - in terms of frame {C} and also in terms of frame {A}. Find the Jacobians in both cases and mention the points of singularity. 20

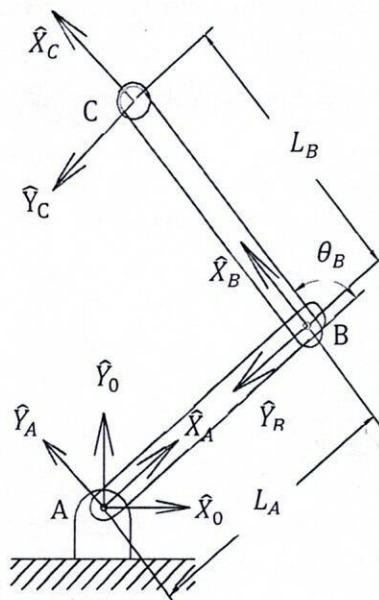

- 4(b) Derive the expression of joint torques of a 2 DOF manipulator with one revolute and one prismatic joint. 15

SECTION-B

- 5(a) Explain the hierarchy of motion planning. Why via points are important in trajectory planning? 07
- 5(b) Define path and trajectory. Differentiate path generation between joint space and cartesian space. 07
- 5(c) Mention the difference in trajectory planning with linear interpolation, cubic polynomial and 5th order polynomial. 09
- 5(d) A single joint of a robot is motionless at $\theta_0 = 10^\circ$. It is desired to move the joint in a smooth manner to $\theta_f = 90^\circ$ in 10 sec. Derive the equation of motion using cubic polynomial and find the position in 3 sec and 6 sec, respectively. 12
- 6(a) Justify with necessary diagram that IR sensor, ultrasonic sensor and laser sensor each works on an individual, distinct principle. 12
- 6(b) With a neat sketch, show how an incremental optical encoder converts gating modulated light into countable edges; Justify three concentric tracks in the circular disk in optical encoder construction. Also briefly explain when rotary optical encoders are preferred to potentiometers. 13
- 6(c) Explain why are strain gauges arranged in Wheatstone resistance bridge. Also, mention two engineering applications where you can use strain gauges. 10
- 7(a) Differentiate electric actuators, pneumatic actuators and hydraulic actuators according to their operation, power consumption and application. 10
- 7(b) Justify the statement- "Brushless DC motor and stepper motor runs on the same physics. 10
- 7(c) A surgery robot should have good accuracy and precision in its movement. Which actuator should be used with closed-loop feedback? If you want to avoid closed loop feedback then which actuator will give you considerable accuracy in movement? Briefly explain. 15
- 8(a) Describe the trajectory following robot control system with necessary block diagram. 12
- 8(b) What are the typical robot programming methods? Write short note on explicit robot programming methods. 13
- 8(c) Explain the application of teach pendant for robot programming. 10

-- END --