

KHULNA UNIVERSITY OF ENGINEERING & TECHNOLOGY
 B.Sc. Engineering 1st Year 1st Term Examination, 2020
 Department of Computer Science and Engineering
 CSE 1107

Discrete Mathematics

TIME: 1.5 hours

FULL MARKS: 120

- N.B. i) Answer **ANY TWO** questions from each section in separate scripts.
 ii) Figures in the right margin indicate full marks.

SECTION A

(Answer **ANY TWO** questions from this section in Script A)

1. a) Define “Contrapositive” and “Inverse” propositions using example(s). (08)
- b) Are $\neg(P \vee Q)$ and $\neg P \wedge \neg Q$ logically equivalent? Prove your answer using a truth table. (07)
- c) Define logical quantifiers using example(s). Prove that $\neg \exists x Q(x) \Leftrightarrow \forall x \neg Q(x)$ (15)
 and $\neg \forall x P(x) \Leftrightarrow \exists x \neg P(x)$.

2. a) What is a graph? Let $G = (V, E)$ be a graph with directed edges. Then prove that (12)

$$\sum_{v \in V} \deg^-(v) = \sum_{v \in V} \deg^+(v) = |E|.$$
- b) What are the necessary and sufficient conditions for two graphs to be isomorphic? Are the (13)
 following two graphs isomorphic? Explain.

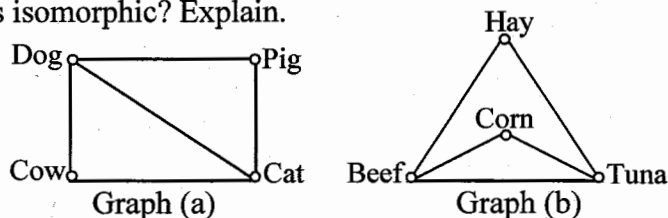

- c) If a and b are positive integers. Then prove that $\gcd(a, b) \cdot \text{lcm}(a, b) = a \cdot b$, where the symbols (05)
 have their usual meaning.
3. a) What is induction method? Use this method to find the orderings of all n -bit strings in a such (13)
 way that two consecutive n -bit strings differ by only one bit.
- b) Provide the recursive definition of the sequence $\{a_n\}$, $n = 0, 1, 2, 3, \dots$, if (i) $a_n = 3n + 2$, (12)
 (ii) $a_n = 3^{n+1}$.
- c) Draw the recursive Fibonacci evaluation tree for $f(5)$, where $f(0) = 0$; $f(1) = 1$ and $f(n) = f(n-1)$ (05)
 $+ f(n-2)$ for $n = 2, 3, 4, 5, \dots$

SECTION B

(Answer **ANY TWO** questions from this section in Script B)

4. a) What is a relation? “Every function is a relation but not every relation is a function” – Justify (10)
 the statement.
- b) Let f be an injective function from the set A to the set B . Let, S and T be subsets of A . Show (10)
 that, $f(S \cap T) = f(S) \cap f(T)$.
- c) Prove that, $\lceil x + n \rceil = \lceil x \rceil + n$. Are $f \circ g$ and $g \circ f$ equal or not? Justify your answer. (10)
5. a) Briefly explain the application of “floor” function and “ceil” function with example. (10)
- b) Discuss symmetric, antisymmetric, reflexive and transitive properties of relation R . (10)
- c) Rasel deposits RM1500 in a local savings bank at an annual interest rate of 13% compounded (10)
 annually. Define recursively the compound amount a_n he will have in his account at the end
 of n years. How much amount will be in his account after 5 years.
6. a) List the ordered pairs in the equivalence relation R produced by the partition $A_1 = \{1, 2\}$, (10)
 $A_2 = \{3, 4\}$ and $A_3 = \{5, 6, 7, 8\}$ of $S = \{1, 2, 3, 4, 5, 6, 7, 8\}$.
- b) During the month of 31 days, a baseball team plays at least one game a day, but no more than (10)
 45 games. Show that, there must be a period of some consecutive days during which each team
 must play exactly 14 games.
- c) Prove that, $[R, x]$ is not a group. Recursively prove that the sequence $\{a_n\}$ of powers of 2 is (10)
 $a^n = 2^n$.

TIME: 1.5 hours

FULL MARKS: 120

- N.B. i) Answer ANY TWO questions from each section in separate scripts.
 ii) Figures in the right margin indicate full marks.

SECTION A

(Answer ANY TWO questions from this section in Script A)

1. a) State and explain Ohm's law, KVL and KCL. (09)
 b) State superposition theorem. Using the theorem, find the current through 10Ω resistance of the circuit shown in the following figure. (15)

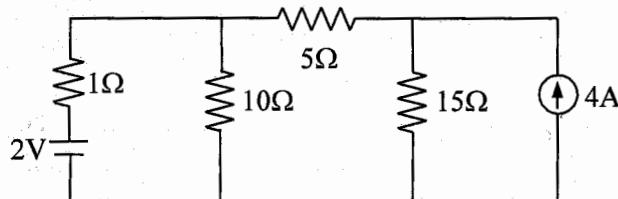

- c) What is electrical source? Classify electrical sources. Define independent and dependent sources. (06)
 2. a) Using nodal analysis find the value of V_1 and V_2 as shown in following figure. (15)

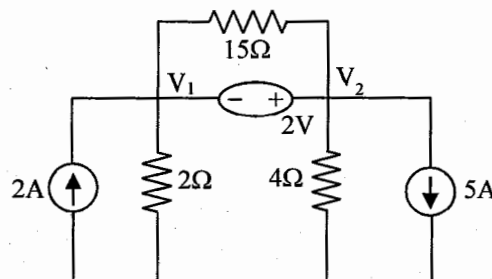

- b) Use mesh analysis to find the value of the currents I_1 , I_2 , and I_3 for the circuit shown below. (15)

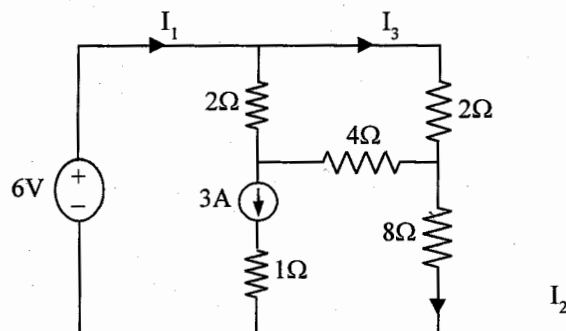

3. a) Briefly explain the working principle of a dc motor. What is back emf and mention the significance of it. (10)
 b) A 230V dc shunt motor has an armature resistance of 0.5Ω and field resistance of 115Ω . At no load, the speed is 1200 rpm and the armature current is 2.5A. On application of rated load, the speed drops to 1120 rpm. Determine the line current and power input when the motor delivers rated load. (10)
 c) State and explain Ampere circuital law. Define (i) Permeability (ii) Reluctance and (iii) Magnetomotive force. (10)

SECTION B

(Answer ANY TWO questions from this section in Script B)

4. a) What is phase? Find the angle of phase difference between $v = 100 \cos(\omega t - 30^\circ)$ and $i = -10 \sin(\omega t - 60^\circ)$. Which wave lags? (08)
 b) Define impedance. Find the impedance of a C branch from its steady-state equilibrium equation. (10)
 c) A voltage $v = 200 \cos(157t + 30^\circ)$ volts is applied to a particular circuit element and it is found $i = 5 \sin(157t - 150^\circ)$ amp. Sketch v and i waves. Find the nature and magnitude of the circuit element. (12)

5. a) Define form factor and crest factor. Find the factors for the sawtooth wave shown in the figure (10) below.

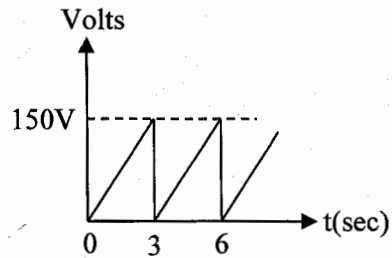

- b) One hundred and ten volts are applied to a series circuit consisting of 8 ohm resistance, (16) 0.0531 henry inductance and 189.7 μf capacitance. When the frequency is 60 cycles, calculate current, power, power factor vars, reactive factor and volt-amp.
- c) What is phasor? Write the significance of operator j . (04)
6. a) Describe the open circuit test and short circuit test of a single phase transformer. Why is (15) transformer rated in KVA.
- b) What are the different types of 3- ϕ transformer connections? Describe them briefly. Write down (15) the advantages and disadvantages of 3- ϕ transformer.

KHULNA UNIVERSITY OF ENGINEERING & TECHNOLOGY
B.Sc. Engineering 1st Year 1st Term Examination, 2020
Department of Computer Science and Engineering
HUM 1107

English and Human Communication

TIME: 1.5 hours

FULL MARKS: 120

- N.B. i) Answer **ANY TWO** questions from each section in separate scripts.
ii) Figures in the right margin indicate full marks.

SECTION A

(Answer **ANY TWO** questions from this section in Script A)

1. a) Frame Wh questions from the underlined parts of the following answers. (10)
i) Dhaka is the capital of Bangladesh.
ii) We found him on the railway platform.
iii) My father is a school teacher.
iv) He has been reading for three hours.
v) He is a studious boy.
- b) Make sentences using the following words as directed. (10)
Phone (as verb); Phone (as adjective); Round (as noun); Round (as preposition); Home (as adverb).
- c) Change the following words as directed and make sentences with the changed words. (10)
Man (into adjective); Act (into verb); picture (into verb); Hospital (into noun).
2. a) Make sentences on the following structures using the verb given in brackets. (10)
i) Subject + intransitive verb + adverbial + extension. (Swim as verb)
ii) Subject + linking verb + noun complement + extension. (Become as verb)
iii) Subject + transitive verb + infinitive as object. (Want as verb)
iv) Subject + transitive verb + object + noun complement. (Consider as verb)
- b) Make sentences using the following models as directed. (10)
i) Could (To express polite request)
ii) Could (To express inference)
iii) Must (To express logical deduction in the present)
iv) Need (To express unnecessary action in the past)
v) Be going to (To express strong possibility)
- c) Make sentences using the following phrases and idioms. (10)
At large; Bad blood; In a fix; Pros and cons; Ad hoc.
3. a) Transform the following sentences as directed. (10)
i) We consider that he is wise and just. (Simple)
ii) The evil that man does even lives after them. (Compound)
iii) He escaped unhurt. (Interrogative)
iv) His house was searched. (Active)
v) He appears to be honest. (Negative)
- b) Make sentences expressing the following notions/emotions. (10)
i) Disapproval ii) Approval iii) Condolence iv) Warning v) Regret
- c) Complete the sentences with subordinate clauses as directed. (10)
i) This is (Noun clause)
ii) Here is some money (Adjective clause)
iii), he will succeed in life. (Adverb clause of reason)
iv) He talks (Adverb clause of manner)

SECTION B

(Answer **ANY TWO** questions from this section in Script B)

4. a) In today's world tablet computers are changing education. Tablets are more convenient than books. They are more portable, and they have more features. Many people believe that in the future, the best jobs will require students to have strong online skills. They also believe that tablets allow students to be more creative. As an example, students in a history class in Singapore are using an app to discover and "rebuild" an ancient city. To start, they take a video (30)

tour of the ancient city of Machu Picchu. With a tablet, they can “take a tour”. It is as if they were really there. Next, they use an app to design their own city. Finally, they turn their designs into a presentation and share them instantly on their screens. The students use creativity to solve their own problems. Teachers also find students are more motivated.

Another advantage of tablet education is that it can improve student’s test score. This is because tablets and other online devices allow teachers to help students in real time. They can also use AI tools that give them useful feedback about student performances.

Still, no technology is perfect. There are the usual problems of lack of internet access and slow wifi connections. Another disadvantage is that students can get easily distracted. Some students end up playing a game or texting their friends. They stop concentrating on the teacher and classroom. This can be frustrating for teachers. Too much distraction can also have a negative impact on student’s grades.

To solve these problems, teachers are going to need more training in using tablets for education. Second, all students need to have reasonable quality devices and good wifi connections. Parents also must learn to adapt to technology. If students, parents, and teachers can work together, this new type of classroom could become the classroom of future.

Read the above passage and answer the following questions.

- i) What are the differences between tablets and books for learning?
 - ii) What are the advantages of tablet education?
 - iii) What are the disadvantages of tablet education?
 - iv) What are some solutions to these disadvantages?
 - v) What is your opinion about tablet education? Explain.
5. a) Write a paragraph on the importance of net neutrality. (10)
- b) Suppose Bangladesh Technical Education Board is looking for a system analyst. Prepare your CV and apply for the post. (20)
6. a) Write a free composition on any one of the followings: (30)
- i) Smart phone dependent society
 - ii) Student behaviour at universities

KHULNA UNIVERSITY OF ENGINEERING & TECHNOLOGY
 B.Sc. Engineering 1st Year 1st Term Examination, 2020
 Department of Computer Science and Engineering
 MATH 1107

Differential and Integral Calculus

TIME: 1.5 hours

FULL MARKS: 120

- N.B. i) Answer **ANY TWO** questions from each section in separate scripts.
 ii) Figures in the right margin indicate full marks.

SECTION A

(Answer **ANY TWO** questions from this section in Script A)

1. a) Define limit and Continuity of a function. A function $f(x)$ is defined as follows (10)

$$f(x) = \begin{cases} 3+2x & \text{for } -\frac{3}{2} < x \leq 0 \\ 3-2x & \text{for } 0 < x \leq \frac{3}{2} \end{cases}$$

Discuss the differentiability of $f(x)$ at any value of x .

- b) Find the maximum value of $\frac{y^4}{(y-1)(y-3)^3}$ (10)

- c) Find the differential coefficient of $(\tan x)^{\cot x} + (\cot x)^{\tan x} = 0$ (10)

2. a) Find the tangent and the normal to the curve $x(y-2)(y-3) - y + 7 = 0$ at the point where it cuts the y -axis. (14)

- b) State Leibnitz's theorem. If $y = (x^2 - 1)^n$, prove that, $(x^2 - 1)y_{n+2} + 2xy_{n+1} - n(n+1)y_n = 0$. (16)

3. a) Define homogeneous function. If $u = \log r$ and $r^2 = x^2 + y^2 + z^2$, then prove that (16)

$$r^2 \left(\frac{\partial^2 u}{\partial x^2} + \frac{\partial^2 u}{\partial y^2} + \frac{\partial^2 u}{\partial z^2} \right) = 1$$

- b) Find the n th derivative of $y = \log(x+b)$. (14)

SECTION B

(Answer **ANY TWO** questions from this section in Script B)

4. Integral the followings (Any two) (30)

(i) $\int \frac{dx}{x\sqrt{2+x-x^2}}$ (ii) $\int \sqrt{\left(\frac{x-5}{x-7}\right)} dx$ (iii) $\int \tan^{-1} x dx$

5. a) Evaluate, $\lim_{n \rightarrow \infty} \left[\frac{1^2}{n^3+1^3} + \frac{2^2}{n^3+2^3} + \frac{3^2}{n^3+3^3} + \dots + \frac{n^2}{2n^3} \right]$ (10)

- b) Evaluate, $\int_0^1 \log\left(x + \frac{1}{x}\right) \frac{dx}{1+x^2}$. (12)

- c) Prove that, $\Gamma(n) = \frac{\Gamma(n+1)}{n}$ (08)

6. a) Find the area enclosed by $xy = 4$, $2x = 5 + 4y - y^2$ and $y = 4$ using double integration. (15)

- b) Evaluate, $\int_0^{\infty} \frac{\log(1+a^2x^2)}{1+b^2x^2} dx$ by using the rule, "Differentiation under the integral sign". (15)

KHULNA UNIVERSITY OF ENGINEERING & TECHNOLOGY
B.Sc. Engineering 1st Year 1st Term Examination, 2020
Department of Computer Science and Engineering
PHY 1107
Physics

TIME: 1.5 hours

FULL MARKS: 120

- N.B. i) Answer **ANY TWO** questions from each section in separate scripts.
ii) Figures in the right margin indicate full marks.

SECTION A

(Answer **ANY TWO** questions from this section in Script A)

1. a) What is Huygen's wave theory of light? What is meant by a wavefront? How is it produced? (10)
b) Achromatism is known as the elimination of the chromatic aberration in a system of lenses. (10)
What are the conditions for achromatism? Also write down the conditions for reduction of spherical aberration.
c) Green light of wavelength 510nm from a narrow slit is incident on a double slit. If the overall separation of 20 fringes on a screen 200cm away is 4cm . Find the slit separation. (10)
2. a) Explain the terms, 'Planck's quantum theory' and 'Wave-particle duality'. (08)
b) Derive an expression for Compton shift and give reason how does it support the concept of photon. (12)
c) X-rays of wavelength 10^{-12}m are scattered from a target. (10)
i) Find the wavelength of the X-rays scattered through 45° .
ii) Find the maximum wavelength present in the scattered X-rays.
3. a) State and prove Heisenberg's uncertainty principle. Discuss its physical importance. (07)
b) Derive the Schrödinger equation for a particle in one-dimensional motion and separate it into time dependent and time independent. (15)
c) An electron has a De-Broglie wavelength of 2pm . Find its kinetic energy and the phase & group velocities of its De-Broglie waves. (08)

SECTION B

(Answer **ANY TWO** questions from this section in Script B)

4. a) What do you mean by a symmetry operation? Describe in detail two-dimensional lattice type. (10)
b) For a cubic crystal structure, find the inter-planer distance or spacing in terms of Miller indices. (10)
c) In a tetragonal lattice $a = b = 2.2 \text{ \AA}$, $c = 1.8 \text{ \AA}$. Find (10)
i) The lattice separation between $[1\ 0\ 2]$ planes.
ii) The density of lattice point in $[1\ 1\ 0]$ planes.
5. a) What are the assumptions of Debye model for lattice specific heat? Discuss predictions of the model and compare it with experimental observations. (12)
b) What do you understand by Fermi energy E_F ? Calculate its value for free electron gas at 0°K . (10)
c) Calculate the maximum phonon frequency generated by scattering of visible light of wavelength $\lambda = 4650 \text{ \AA}$. Given that the velocity of sound in medium is $4.6 \times 10^5 \text{ cm/sec}$ and refractive index is 1.5. (08)
6. a) Give the brief outlines of the form of input energy of a LASER. Give some characteristics properties of a LASER light. (11)
b) Explain how laser activity happens in He-Ne lasers starting with the appropriate diagram. (10)
c) The coherence length of sodium D_2 -line is 2.5cm . Deduce the (09)
i) Coherence time.
ii) Spectral width of the line.
iii) Purity factor, Given $\lambda = 5896 \text{ \AA}$