

KHULNA UNIVERSITY OF ENGINEERING & TECHNOLOGY
B.Sc. Engineering 1st Year 2nd Term Examination, 2019
Department of Computer Science and Engineering
CSE 1201
Structured Programming

TIME: 3 hours

FULL MARKS: 210

- N.B. i) Answer **ANY THREE** questions from each section in separate scripts.
ii) Figures in the right margin indicate full marks.

SECTION A

(Answer **ANY THREE** questions from this section in Script A)

1. a) Describe the basic structure of a C program with its different sections. (12)
b) Suppose, "AAS" is a signed integer data type of size 6 bits with format specifier "%a". Then explain the following code segment. (10)

```
AAS var = 127;
printf("%a", var);
```

c) Write down the five variable naming rules. (05)
d) What is control instruction of C program? Give example. (08)
2. a) Describe priority and associativity of operators with proper examples. (07)
b) If, `int x = 2147483647, y = 3, z = 10;` determine the values of the following expressions: (09)
i) `~x + z % y;`
ii) `!z ^ !!y ? 0:1;`
iii) `z >>= y + (7&8);`
c) Show implicit and explicit type conversion with example(s). (09)
d) Explain the output of the following program. (10)

```
#include <stdio.h>
int main()
{
    int a = 1, b = 9;
    a <<= 1;
    if(a == 1 && b++ == 9);
    printf("a=%d, b=%d\n", a, b);
}
```
3. a) Write a C program to show total number of prime numbers up to N, where N is an integer number and taken from user. (10)
b) What are the differences between "else if ladder" and "switch case structure"? (10)
c) Draw the working flowchart of "do while" loop. (05)
d) Is there any problem in the following program? If "no" then what is the output? Otherwise solve the problem. (10)

```
#include <stdio.h>
int main()
{
    int arr[15], i;
    for(i=0; i<25; i++)
        arr[i] = i;
    for(i=0; i<15; i++)
        printf("%d", arr[i]);
}
```
4. a) Consider, two strings "CSE" and "KUET". Design a user define function "Catenation (char *, char *)" having two parameters of character type pointer and only task of that function is to concatenate one string after another. For example, Catenation ("CSE", "KUET") produce "CSEKUET". (12)
b) What is the limitation of 2-Dimensional array? (08)
c) Why do you use array of pointers to string? Discuss the problem of it and how do you solve this problem? (15)

SECTION B

(Answer ANY THREE questions from this section in Script B)

5. a) Explain why different types of pointer variables are needed although we only store address in a pointer variable in C language. (06)
- b) Using the concepts of byte copying and function pointers, create a generic array sorting function in C. Also, explain your code and show a sample use case. (20)
- c) Explain with proper memory diagram if it is safe to return address of a local variable using address of operator (&) or via pointer variable. (09)
6. a) Discuss the relationship between array and pointer. (07)
- b) Is it possible to return multiple values from a function? Create a function to swap two variables using call by reference. (08)
- c) Create a variadic function find average of varying number of parameters. The types of parameters can be either integer, float or double which will be provided in a string as shown below: (15)
- ```
average("i f d i f", 5, 2.3, 3.5, 10, 2.8)
```
- where, i means integer, f means float and d means double.
- d) Why is typedef used? Explain with example. (05)
7. a) What is recursion? Write a program to solve Tower of Hanoi problem using recursion. (10)
- b) What is the buffer overflow problem of gets()? How fgets() can solve the problem? Explain. (06)
- c) Give an example of memory leak. Write your own implementation of the realloc() function. (15)
- d) How does free() function work without a size argument? (04)
8. a) Explain the output of the following printf(): (10)
- ```
printf("%#012X", 14);
```
- Also, show the uses sscanf() and sprintf() functions.
- b) Why structure padding is used? How can we turn off this feature? Calculate size of the following structures considering structure padding: (10)
- | | |
|---|--|
| i) struct structa{
char c;
int i:3;
char d;
} | ii) struct structb{
char c;
double d;
int i;
} |
|---|--|
- c) Write a C program using fread() and fwrite() function to do file operations on a structure variable. Also, explain how fseek() can be used to read a specified structure variable from file. (10)
- d) Explain the necessity of union with an example. (05)

KHULNA UNIVERSITY OF ENGINEERING & TECHNOLOGY
 B.Sc. Engineering 1st Year 2nd Term Examination, 2019
 Department of Computer Science and Engineering
 CSE 1203
 Digital Logic Design

TIME: 3 hours

FULL MARKS: 210

- N.B. i) Answer **ANY THREE** questions from each section in separate scripts.
 ii) Figures in the right margin indicate full marks.

SECTION A

(Answer **ANY THREE** questions from this section in Script A)

1. a) What is Gray Code? Determine a combination for Gray Code. (08)
- b) Find the complement of the following Boolean function and reduce them to minimum number of literals: $F = (BC' + A'D)(AB' + CD')$ (08)
- c) There is a secured room having an electric lock with four keys. The keys have the following weights. (12)

Key Number	Weight
1	45
2	35
3	15
4	20

The lock can be opened if at least 38 weights are generated. Design a combinational circuit for this lock.

- d) What is the difference between canonical form and standard form? Which form is preferable when implementing a Boolean function with gates? Which form is obtained when reading function from a truth table? (07)
2. a) Show that a positive-logic AND gate is a negative logic-OR gate and vice versa. (08)
 - b) Obtain the simplified expression in product of sum: (08)
 $F(A, B, C, D) = \pi(0,1,2,3,4,10,11)$.
 - c) Implement the following function with either NAND or NOR gates. Use only four gates. Only the normal inputs are available. (10)

$$F = w'xz + w'yz + x'yz' + wxy'z$$

$$d = wyz$$
 - d) Show that it is possible to convert a full-adder into a full-subtractor by merely complementing input x prior to its application to the gates that form the carry output. (09)
3. a) What is carry propagation delay in a full-adder circuit? Show that carry propagation problem can be eliminated by designing a carry look-ahead generator. (12)
 - b) Justify that any combination of four adjacent squares in the three variable map results in an expression of only one literal. (07)
 - c) Determine the prime implicants and essential prime implicants of the function: (11)
 $F(w, x, y, z) = \sum(1,4,6,7,8,9,10,11,15)$ and then returned minimized function.
 - d) What is essential prime implicant? (05)
4. a) What are (i) Demultiplexer, (ii) Priority Encoders? (07)
 - b) What is the significance of Quadruple 2 to 1 line multiplexer? Implement the following function with a multiplexer. (12)

$$F(A, B, C, D) = \sum(0,1,3,4,8,9,15)$$
 - c) Construct a 5×32 decoder with four 3×8 decoders and a 2×4 decoder. (06)
 - d) Determine the Boolean function for the output F of the circuit as shown in the following figure. Obtain an equivalent circuit with fewer NOR gates. (10)

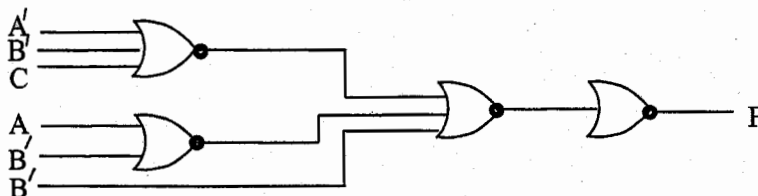

SECTION B

(Answer ANY THREE questions from this section in Script B)

5. a) How does sequential circuit differ from combinational circuit? (05)
 b) Write down the truth table, characteristic table and excitation table of JK flip-flop and also draw the logic diagram of JK flip-flop. (10)
 c) Convert a SR flip-flop into a JK flip-flop and vice versa. (10)
 d) Design a synchronous counter with the sequence given below: (10)
 1→4→5→7→2→1

6. a) What are the rules for state reduction? Reduce the number of states in the following state table and tabulate the reduced state table. (12)

Present State	Next State		Output	
	x = 0	x = 1	x = 0	x = 1
A	F	B	0	0
B	D	C	0	0
C	F	E	0	0
D	G	A	1	0
E	D	C	0	0
F	F	B	1	1
G	G	H	0	1
H	G	A	1	0

- b) The full-adder shown in the following figure receives two external inputs x and y ; the third input z comes from the output of a D flip-flop. The carry output is transferred to the flip-flop every clock pulse. The external s output gives the sum of x , y , and z . Obtain the state table, state diagram and state equation of the sequential circuit. (12)

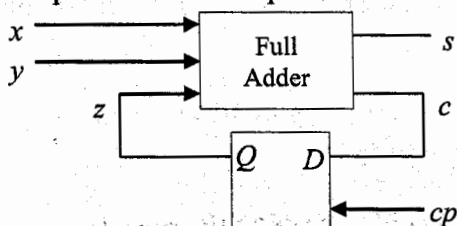

- c) Design the sequential circuit described by the following state equations. Use JK flip-flops. (11)

$$A(t+1) = xAB + yA'C + xy$$

$$B(t+1) = xAC + y'BC'$$

$$C(t+1) = x'B + yAB'$$

7. a) Design a sequential circuit with two D FFs, A and B, and one input x . When $x = 0$, the state of the circuit remains same. When $x = 1$, the circuit goes through the state transitions from 00 to 01 to 11 to 10 back to 00 and repeats. (10)
 b) The content of a 4-bit shift register is initially 1101. The register is shifted six times to the right, with the serial input being 101101. What is the content of the register after each shift? (05)
 c) Draw the diagram of a 4-bit binary ripple counter using flip-flops that trigger on the positive edge and explain its operation. (10)
 d) Show the design of a 4-bit parallel load register with a load line using D flip-flop. (10)
8. a) Define self-complementing code. "Unit distance code is self-complementing"-justify your answer. (06)
 b) Design a 4096 bit ROM whose word size is 4-bit. (05)
 c) What is PLA? What are the advantages of PLA over ROM? (07)
 d) Derive the PLA program table for a combinational circuit that squares a 3-bit binary number. Minimize the number of product terms. (17)

KHULNA UNIVERSITY OF ENGINEERING & TECHNOLOGY
B.Sc. Engineering 1st Year 2nd Term Examination, 2019
Department of Computer Science and Engineering
CHEM 1207
Chemistry

TIME: 3 hours

FULL MARKS: 210

- N.B. i) Answer **ANY THREE** questions from each section in separate scripts.
ii) Figures in the right margin indicate full marks.

SECTION A

(Answer **ANY THREE** questions from this section in Script A)

1. a) Define isomorphism. Illustrate with examples-unit cell of seven crystal systems. (10)
b) Deduce Bragg's law for X-RD. (08)
c) Find the interplanar distance in a crystal in which a series of planes produce a first order reflection from a Cu-xray tube ($\lambda = 1.539 \text{ \AA}$) at an angle of 22.5°C . (07)
d) Draw the crystal structure of Si. "Silicon is superior to Germanium in a semiconductor device"-explain. (10)
2. a) What are the differences between cell and battery? Discuss the working principle of Lithium ion battery. (10)
b) Deduce Nernst equation for determining EMF. (10)
c) What current strength in amperes will be required to liberate 10g of Iodine from KI solution in one hour? (07)
d) Briefly explain the importance of double layer capacitance in electrochemistry. (08)
3. a) What is quantization of energy? Relate Planck's theory to explain it. (10)
b) Draw a flow diagram of uv-vis spectroscopy. Explain the function of monochromator and detector in uv-vis spectroscopy. (10)
c) Deduce Beer's-Lambert law in spectroscopy. (07)
d) Illustrate different vibrational mode in IR spectroscopy. (08)
4. a) Write down the reactions involved on anode and cathode in Ni-Cd battery. Mention few applications of Ni-Cd battery. (10)
b) Discuss the symmetry of crystals. (10)
c) "SiCl₄ is very reactive, but CCl₄ inert"-explain. (07)
d) Write short notes on: (i) Band spectra (ii) Line spectra. (08)

SECTION B

(Answer **ANY THREE** questions from this section in Script B)

5. a) Define photochemical and thermal reactions with examples. (08)
b) State and explain the law of photochemistry. (12)
c) A photochemical reaction absorbs 10^{-4} Einstein energy. What is the quantum yield of the reaction? (08)
d) Explain photosensitized reaction with example. (07)
6. a) What is the role of hydrogen bonding on the existence of the earth? (08)
b) State and explain the MOT with suitable example. (12)
c) Calculate the bond order and predict about magnetic nature of O₂ molecule considering MOT. (08)
d) Copper (Cu) is good conductor. Explain the mechanism. (07)
7. a) Define monomer, polymer and conducting polymer with examples. (07)
b) Discuss the free radical polymerization mechanism. (10)
c) Nylon polymer shows high strength. Explain the mechanism. (08)
d) What do you mean by isotactic, syndiotactic and atactic polymers? Explain. (10)
8. a) Write down the structure of the vulcanized rubber. (07)
b) Synthesize Bakelite polymer and nylon-6 fibre. (10)
c) What do you mean by fluorescence and chemiluminescence? Explain. (08)
d) Discuss the electron sea model of metallic bonding. (10)

KHULNA UNIVERSITY OF ENGINEERING & TECHNOLOGY
 B.Sc. Engineering 1st Year 2nd Term Examination, 2019
 Department of Computer Science and Engineering
 MATH 1207

Coordinate Geometry and Differential Equations

TIME: 3 hours

FULL MARKS: 210

N.B. i) Answer **ANY THREE** questions from each section in separate scripts.

ii) Figures in the right margin indicate full marks.

SECTION A

(Answer **ANY THREE** questions from this section in Script A)

1. a) Define invariants. Find the angle through which the axes must be rotated to remove the xy -term from the equation of $-x^2 + 4xy - 3y^2 - 9 = 0$. Also, find the transformed equation of it, when the axes are rotated through an angle $\tan^{-1}(2)$. (15)
- b) Identify the conic, $2x^2 + y^2 - 3xy - 5x + 4y + 6 = 0$. Also, find its transformed equation when the origin is shifted at its center. (12)
- c) Find the transformed coordinates of $(-2,1)$ with respect to $12x + 5y + 1 = 0$ and $5x - 12y + 1 = 0$ as the x -axis and y -axis, respectively. (08)
2. a) Find the cartesian and spherical polar coordinates for the point, whose cylindrical polar coordinates are $(-2\sqrt{2}, \tan^{-1}(-\frac{1}{2}), 3)$. (10)
- b) Find the equation of the right circular cylinder of radius 2 whose axis passes through $(-1, 2, 3)$ and its direction ratios 1, 0, -2. (13)
- c) Test whether the four points $(0, 1, 2), (3, 0, 1), (4, 3, 6)$ and $(2, 3, 2)$ are coplanar or not. If they are non-coplanar then find the volume of the tetrahedron whose vertices are these four points. (12)
3. a) Define direction cosines of a line with an example. Find the direction cosines and equation of a line, which is perpendicular to the xy -plane and passes through a point placed at xy -plane, whose x and y coordinates are -2 and 4 respectively. (11)
- b) Find the distance from the point $(-1, 2, 3)$ to the plane $x + y - z - 14 = 0$ measured parallel to the line $\frac{x-2}{2} = \frac{y+4}{1} = \frac{z-5}{-2}$. (12)
- c) Verify whether the lines $\frac{x-1}{2} = \frac{y}{-3} = \frac{z+2}{-1}$ and $\frac{x}{-1} = \frac{y+3}{-2} = \frac{z-2}{1}$ are coplanar or not. If coplanar then find the equation of the plane containing them. (12)
4. a) Find the length of the shortest distance between two skew lines $x + y = 0, z = 0$ and $\frac{x-3}{4} = \frac{y-2}{3} = \frac{z-1}{-6}$. (13)
- b) A variable plane is at a constant distance p from the origin and meets the axes in A, B, C . Show that the locus of the centroid of the tetrahedron $OABC$ is $x^{-2} + y^{-2} + z^{-2} = 16p^{-2}$. (11)
- c) Define great circle. Find the equation of a sphere in which the circle $x^2 + y^2 + z^2 - 7y + 2z - 2 = 0, 2x - 3y - 4z + 24 = 0$ is a great circle. (11)

SECTION B

(Answer **ANY THREE** questions from this section in Script B)

5. a) Define degree of a differential equation (DE) with example. Form the DE of all parabolas which foci at the origin and the axis along the x -axis. (12)
- b) For the certain value of constant n the function g is defined by $g(x) = x^n$ is a solution of the DE, $x^3 \frac{d^3 y}{dx^3} + 2x^2 \frac{d^2 y}{dx^2} - 10x \frac{dy}{dx} - 8y = 0$. (11)
- c) Solve the initial value problem, $(2x \cos y + 3x^2 y)dx + (x^3 - x^2 \sin y - y)dy = 0; y(0) = 2$. (12)

6. Answer any three of the followings: (35)

i) Find a particular solution of $y(x^2y^2 + 2)dx + x(2 - 2x^2y^2)dy = 0$; $y(1) = 1$.

ii) Solve $(\frac{d^2y}{dx^2} - 2\frac{dy}{dx} + 3y) = x^3 + \sin x$ by UC method.

iii) Solve $\frac{dy}{dx} + \frac{y}{x} = x^3y^3$.

iv) Solve the DE, $\frac{d^3y}{dx^3} + 27y = 0$.

7. Answer any three of the followings: (35)

i) Solve the DE, $(D^2 + 2)y = \sec x$, where $\frac{d}{dx} = D$.

ii) Solve the initial value problem $\frac{d^2y}{dx^2} - 6\frac{dy}{dx} + 25y = 0$; $y(0) = -3$; $y'(0) = -1$.

iii) Solve $(\frac{d^4y}{dx^4} + 2\frac{d^3y}{dx^3} - 3\frac{d^2y}{dx^2}) = x^2 + 3e^{2x} + 4\sin x$.

iv) Solve the DE, $(D^2 + 6D + 9)y = \frac{e^{-3x}}{x^3}$ by using the method of variation of parameter.

8. a) Solve $\frac{d^2y}{dx^2} - x^2\frac{dy}{dx} - y = 0$ in power of x . (17)

b) Solve the following boundary value problem by the method of separation of variables. (18)

$$\frac{\partial u}{\partial t} = 4\frac{\partial^2 u}{\partial x^2}, u(0, t) = 0, u(\pi, t) = 0, u(x, 0) = 2\sin 3x - 4\sin 5x.$$

KHULNA UNIVERSITY OF ENGINEERING & TECHNOLOGY
 B.Sc. Engineering 1st Year 2nd Term Examination, 2019
 Department of Computer Science and Engineering
 EEE 1217
 Analog Electronics

TIME: 3 hours

FULL MARKS: 210

- N.B. i) Answer **ANY THREE** questions from each section in separate scripts.
 ii) Figures in the right margin indicate full marks.

SECTION A

(Answer **ANY THREE** questions from this section in Script A)

1. a) What is the basic difference between electrical and electronics? Why the study of analog electronics is needed? (08)
- b) Why P-N junction is used as a rectifier? Explain the effects of forward and reverse biasing on the depletion layer of P-N junction with necessary illustration. (08)
- c) Draw the circuit diagram of different full-wave rectifier. Also, find out the expression of their efficiency and ripple factor. (12)
- d) Determine V_0 and I_D for the series circuit of the following figure. (07)

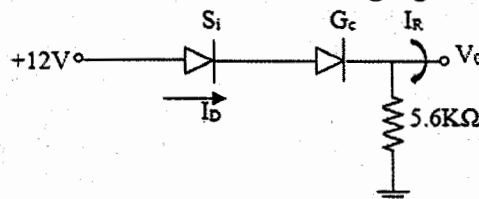

2. a) "A Zener Diode can act as a voltage stabilizer" – Justify your answer with necessary diagrams. (07)
- b) What is meant by faithful amplification? Explain the requirements of faithful amplification with proper schematics. (08)
- c) Explain transistor biasing. Briefly explain different operating regions of transistor. Why mid-point biasing is good for an amplifier circuit? (10)
- d) For a n-p-n transistor, show that (i) $I_c = \frac{\alpha}{1-\alpha} I_B + \frac{I_{CBO}}{1-\alpha}$, (ii) $\beta = \frac{\alpha}{1-\alpha}$, and (iii) $S = \frac{\beta+1}{1-\beta \frac{dI_B}{dI_C}}$, (10)
 where the symbols have their usual meanings.
3. a) Explain the operation of Darlington pair circuit and derive the relation of overall current gain β . (08)
- b) Briefly explain thermal runaway. How can you protect an amplifier from thermal runaway? (07)
- c) Draw the AC and DC equivalent circuit of a common emitter amplifier and find out the expression for voltage gain. (10)
- d) Determine the dc bias voltage V_{CE} and the current I_C for the voltage-divider configuration of the following figure. (10)

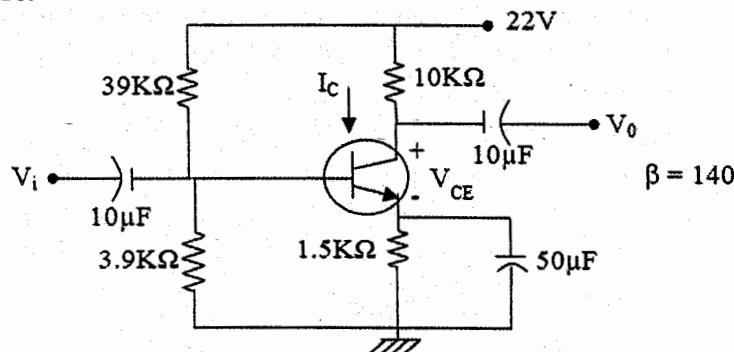

4. a) Why JFET is called a voltage control device? Explain the construction and working principle of a JFET. (12)
- b) Design a CMOS circuit which act as a logic inverter. Also, write down the major differences between D-MOSFET and E-MOSFET. (10)
- c) Draw the structure of a p-channel enhancement type MOSFET. In a self-bias n-channel JFET, the operating point is to be set at $I_D = 1.5\text{mA}$ and $V_{DS} = 10\text{V}$. The JFET parameters are $I_{DSS} = 5\text{mA}$ and $V_P = -2\text{V}$. Find the values of R_S and R_D . Given that $V_{DD} = 20\text{V}$. (13)

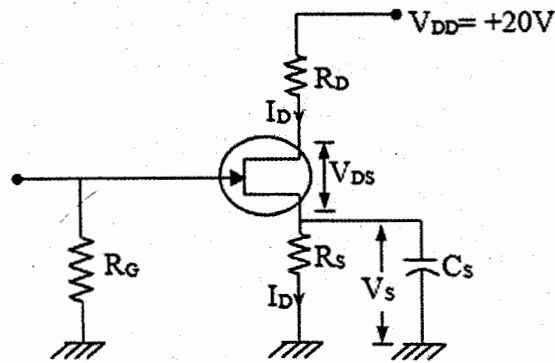

SECTION B

(Answer ANY THREE questions from this section in Script B)

5. a) With neat sketch, explain the working principle of SCR half-wave rectifier. Also, derive the expression of output voltage and current. (09)
- b) Draw the characteristics curve of SCR, DIAC, and TRIAC. Also, mention some of their applications. (12)
- c) Given the relaxation oscillator of the following figure. (14)

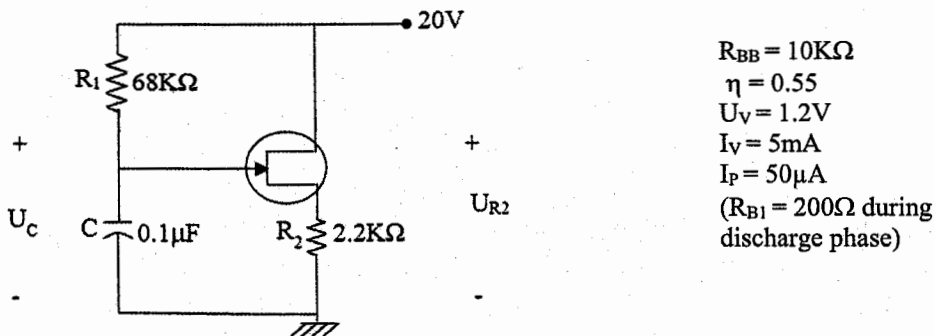

- i) Find R_{B1} and R_{B2} at $I_E = 0A$.
 - ii) Determine V_P , the voltage necessary to turn on the UJT.
 - iii) Determine whether R_1 is within the permissible range or not.
 - iv) Determine the frequency of oscillation if $R_{B1} = 200\Omega$ during the discharge phase.
 - v) Sketch the waveform of U_C and U_{R2} for two full cycles.
6. a) Draw the constructional diagram of TRIAC and DIAC. Design and explain a lamp dimmer circuit using DIAC and TRIAC. (10)
 - b) What are the basic differences between UPS and IPS? Explain three different types of UPS with proper diagram. (10)
 - c) Design a dc power supply to provide an output of +9V, 100mA from 1- ϕ ac mains (220V, 50Hz). Also, identify the important test points and hence draw their wave shapes. (07)
 - d) Calculate the cut-off frequency and voltage gain of a second order high pass filter for the following figure: where $R_1 = R_2 = 2.2K\Omega$, $C_1 = C_2 = 0.10\mu F$, $R_G = 12K\Omega$ and $R_F = 50K\Omega$. (08)

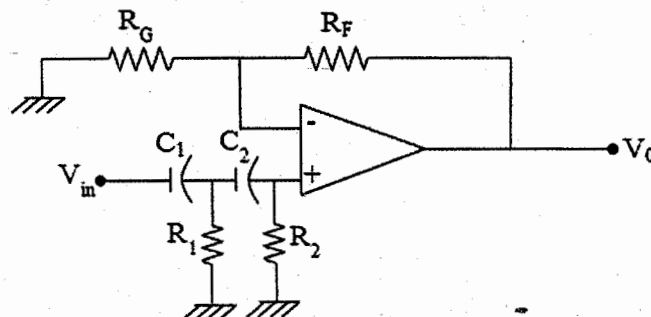

7. a) What is operational amplifier (OP-AMP)? Mention the basic features of an OP-AMP over BJT amplifier. Briefly explain CMRR. (10)
- b) Design an op-amp circuit which acts as a voltage summing and differentiator. Also, mathematically analyze how it works as a summing amplifier and differentiator, use necessary diagrams. (10)
- c) Prove that $V_0/V_1 = -(R_f/R_1)$ for inverting amplifier circuit, where symbols bear their usual meanings. (10)

- d) Calculate the output voltage from the circuit of the following figure for an input $120 \mu\text{V}$. (05)

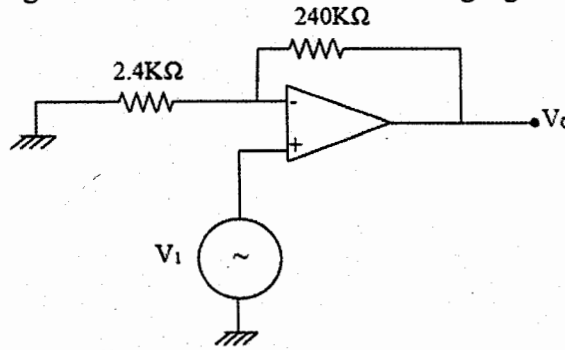

8. a) Why IC is needed? Classify IC. How a transistor is formed in a monolithic IC, explain with necessary diagrams. (14)
- b) Discuss the importance of oscillator. An oscillator is a positive feedback circuit. How the correct phase is obtained for different oscillators. Give logical explanation shortly. (10)
- c) Why crystal oscillator is better than RC or LC oscillators? Draw the equivalent circuit of a crystal oscillator. The ac equivalent circuit of a crystal has values of $L = 1\text{H}$, $C = 0.01\text{pF}$, $R = 1000\Omega$ and $C_m = 20\text{pF}$. Calculate f_s and f_p of the crystal. (11)