

KHULNA UNIVERSITY OF ENGINEERING & TECHNOLOGY
B.Sc. Engineering 2nd Year 1st Term Examination, 2022
Department of Computer Science and Engineering
CSE 2101

Object Oriented Programming

TIME: 3 hours

FULL MARKS: 210

- N.B. i) Answer **ANY THREE** questions from each section in separate scripts.
ii) Figures in the right margin indicate full marks.

SECTION A

(Answer **ANY THREE** questions from this section in Script A)

1. a) What are the advantages of using classes over structure in C++? Describe briefly. (08)
b) Consider the following program. What issues might occur in the given code? How can you solve the problem using smart pointer? Explain with proper code. (12)

```
void fun()
{
    int* dynamicInt = new int(5);
}
int main(){
    while(1){
        fun();
    }
}
```

- c) How does the C++ compiler differentiate between prefix and postfix increment operators? Consider the class shown below. Design the increment operator overloading in a way that the prefix increment operator increments the 'real' value by 1, while the postfix increment operator increments the 'imaginary' value by 1. (15)

```
class Complex {
public:
    float real, imaginary;
};
```

2. a) What is a default constructor? Is it necessary to define the default constructor explicitly? Explain with proper examples. (10)
b) You want to store the result of different courses you attended this semester. So, you decided use a generic class 'Result' that has two member variables – 'course_code' which is a string by default but can vary, and 'course_outcome' which can be a grade point (float), obtained mark (int) or letter grade (string). Now, design the generic class 'Result' with parameterized and default constructor. (15)
c) In C++, both 'new' and 'malloc' can be used to allocate memory dynamically. Which method will you prefer? Defend your answer with proper example. (10)
3. a) What do you mean by associative container? Differentiate between – (i) queue and priority-queue, (ii) map and multi-map. (11)
b) Consider the program shown below. What will be the output of the program? Justify your answer. Re-design the program using exception specifier so that the exceptions are caught in main function. (14)

```
template <typename T>
void exceptionHandler(T c){
    try{throw c;}
    catch(char c){cout << "Caught a character\n";}
    catch(int x){cout << "Caught an integer\n";}
    catch(double d){cout << "Caught a double\n";}
}
int main(){
    exceptionHandler('a'-0);
}
```

- c) Describe the distinction between static variable and global variable. In what scenarios would you opt for using one over another? (10)

4. a) Consider the following program. Apply operator overloading to overload required operators of Student class, such that the program executes without any error. (12)

<pre>class Student{ public: string name; int roll; double cg; };</pre>	<pre>int main(){ ifstream in("input.txt"); ofstream out("output.txt"); Student s; in>>s; out<<s; }</pre>
--	--

- b) How does the compiler resolve the ambiguity when a template function is overloaded with both template functions and regular function? (08)
- c) “dynamic_cast’ and ‘typeid’ operators can be used interchangeably.” Is the statement true? Justify your answer with proper example. (10)
- d) Is it possible to have multiple destructors for a single class? Explain your answer. (05)

SECTION B

(Answer ANY THREE questions from this section in Script B)

5. a) What do you mean by Is-A relation and Has-A relation in OOP? Discuss with coding example. (10)
- b) Explain static binding and dynamic binding in polymorphism with necessary coding examples. (14)
- c) What problem arises in the following code? Solve the problem by correcting the code, then predict the output. (11)

<pre>class A{ public: A(){cout<<"A Constructor\n";} ~A(){cout<<"A Destructor\n";} }; class B: public A{ public: B(){cout<<"B Constructor\n";} ~B(){cout<<"B Destructor\n";} };</pre>	<pre>class C: public B{ public: C(){cout<<"C Constructor\n";} ~C(){cout<<"C Destructor\n";} }; int main(){ A *a; a = new C; delete a; return 0;}</pre>
--	--

6. a) Why is pure virtual function necessary? Explain with proper example. (10)
- b) Write down the constructor calling order sequences in Hybrid inheritance. Demonstrate with necessary coding example(s). (10)
- c) In KUET, there are three types of people namely students, teachers, and officers. The students may be undergraduate or graduate students. Some of the teachers and officers are graduate students. Design a class diagram for KUET people and define the class in C++ (15)
7. a) Briefly explain RTTI and dynamic casting. Also include some examples of it. (10)
- b) Why there a virtual function is necessary in the base class for applying RTTI? Can you implement your own version of RTTI? Explain with coding example. (13)
- c) Consider the following code segment. Modify the function treatAnimal so that, it can count the total number Dog objects it has treated using RTTI. Also call the bark method from Dog class if the current object pointed by pointer p is of type Dog using dynamic casting. (12)

<pre>class Animal{ public: virtual void treat()=0; }; class Cat: public Animal{ public: void treat(){cout<<"Cat\n";} };</pre>	<pre>class Dog: public Animal{ void treat(){cout<<"Dog\n";} void bark(){cout<<"Woof\n";} }; void treatAnimal(Animal *p){ p->treat(); }</pre>
---	---

8. a) Explain “Abstract classes cannot be used to instantiate object and serves only as an interface” with necessary example(s). (10)
- b) What is namespace? How exception handling works in C++? Explain with coding examples with the necessity of it. (10)
- c) Design a C++ program to add two 2 × 2 matrix of complex numbers. Write the declaration of complex number class into ComplexNumber.h file and definition into ComplexNumber.cpp file. Then create a template class Matrix to perform matrix addition. (15)

- N.B. i) Answer **ANY THREE** questions from each section in separate scripts.
 ii) Figures in the right margin indicate full marks.

SECTION A

(Answer **ANY THREE** questions from this section in Script A)

1. a) What do you mean by data structure? What are the basic operations of data structure? (09)
- b) How to calculate the element address in two-dimensional array. Consider the linear array AA[40: 90] and BB[-10: 70]. (11)
 - (i) Find the number of elements in each array.
 - (ii) Suppose Base (AA) = 500 and w = 8 words per memory cell for AA. Find the address AA[75] and AA[69].
- c) What is the time complexity for performing basic operations in an array? (08)
- d) Mention some advantages and disadvantages of arrays. (07)
2. a) Suppose the following operations are performed, in the order given, beginning with an empty structure: (15)
 - (i) push(2), (ii) push (1), (iii) getTop, (iv) push(3), (v) getTop, (vi) pop, (vii) push(4), (viii) getTop, (ix) pop, (x) getTop, (xi) pop, (xii) getTop, (xiii) pop.
 Answer the following questions:
 - (i) If these operations are performed on a stack, what values are returned by the five getTop operations (give them in order)? Remember that getTop does not alter the stack.
 - (ii) Suppose we replace “push” with “enqueue”, “pop” with “dequeue”, and “getTop” with “getFront”, We perform the operations on a queue. What values are returned by the five getFront operations (give them in order)?
 - (iii) Do a similar replacement, and answer the same question for a priority queue in which higher values come out first.
- b) Translate the infix expression (10)

$K + L - M * N + (O \wedge P) * W / U / V * T + Q$

 to its equivalent postfix expression. Which data structure is needed for this task?
- c) What are the moves allowed by the solution of Towers of Hanoi problem when $n = 4$ disks? (10)
3. a) Suppose a data set S contains n elements. Compare the time complexity T[1] of linear search (10) algorithm with the time complexity T[2] of the binary search algorithm when (i) $n = 1000$ and (ii) $n = 10000$.
- b) Consider the following binary search tree (15)

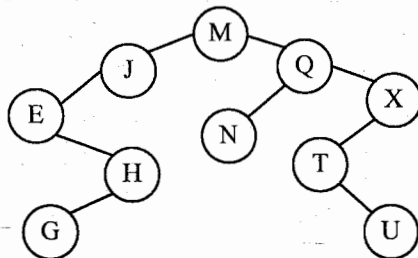

- (i) Write the reverse post order traversal of the binary tree above.
- (ii) What is the depth of the binary tree above?
- (iii) Draw the binary search tree after the node containing M is removed.
- c) The pre-order and In-order traversal of a tree T yield the following sequence of nodes. (10)

Pre-order : 30, 20, 10, 12, 40, 37, 45
 In-order : 10, 12, 20, 30, 37, 40, 45

Draw the diagram of the T.

4. a) What do you mean by heap and heap property? (07)
- b) Construct a down heap H from the following list of numbers: 20, 25, 35, 38, 50, 2, 55, 77, 82, 22 (13)
 - (i) Insert another item 70 into constructed heap.
 - (ii) Then delete the number 22 for replacing it. What are the correct steps in both cases.
- c) Let you are given a postfix arithmetic expression write an algorithm to evaluate the value of the given expression. (08)
- d) Define recursion. Let a , and b denotes positive integers. Suppose a function Q is defined recursively (07) as follows:

$$Q(a, b) = \begin{cases} 0 & \text{if } a < b \\ Q(a - b, b) + 1 & \text{if } b \leq a \end{cases}$$

Find the value of $Q(14, 3)$

SECTION B

(Answer ANY THREE questions from this section in Script B)

5. a) Consider linked lists with each node having two fields named INFO and LINK to store data value and address. A pointer HEAD1 Point to 10. HEAD1: 10 → 20 → 30 → 40 → 50 → 60 Now, design a simple function to perform clock-wise Rotation on HEAD1 by k nodes such that HEAD1: 50 → 60 → 10 → 20 → 30 → 40 for $K = 2$. (10)
- b) Calculate the effectiveness after compressing the text "MISSISSIPPI RIVER" using Huffman Encoding. (10)
- c) Demonstrate Quick Sort with necessary variable changes in the algorithm for following data. Which partitioning techniques would you choose, Lomuto's or Hoare's Partition? Apply your choice during Partitioning. Data : 10, 20, 30, 60, 70, 80, 50, 90. (15)

6. a) Create an AVL tree from the DATA in the given sequence. After creating, delete 45 and 20 sequentially from the final tree (If necessary, replace node with inorder- successor). (12)
Data: 60, 50, 55, 45, 70, 80, 52, 32, 27, 47, 54, 20.

- b) What is the order of the B tree for the following figure? Show the new tree after insertion of the records with the key values 135, 200, 100 to the tree if it's a proper tree structure? (10)

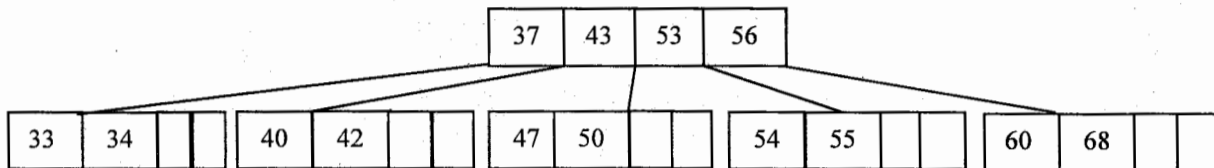

- c) Why is heap preferred while implementing a priority Queue? Construct a Priority Queue using Max Heap for the following elements 8, 56, 13, 34, 55, 86, 99, 12, 17. (13)

7. a) Apply a suitable searching technique to find 80 from the following marks of 15 students. Explain why you choose this technique. (10)

Marks: 62, 72, 74, 75, 76, 77, 77, 80, 85, 86, 88, 88, 90, 92, 95.

- b) Apply Breadth First Search (BFS) algorithm on the graph G shown in the following figure to find minimum path P from A to K . Show the queue status after each iteration. (15)

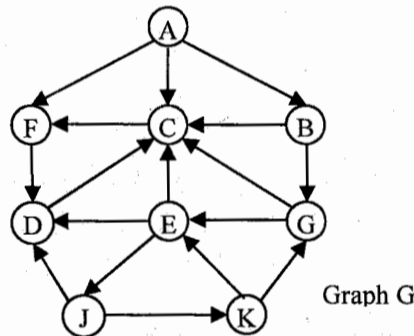

- c) Explain the terms: Complete graph, directed graph, degree of node in a graph. Calculate degree of each node of graph G in figure 7(b). (10)

8. a) Differentiate Heap and BST and also give use case of BST and Heap. (08)

- b) Consider a Hash Table of size $m = 11$ with hash function $h(k) = k \text{ mod } m$. Draw the table that result after inserting in the given order, the values 75, 66, 42, 91, 100, 37, 26 for each of the scenario below: (15)
 - (i) When collisions are handled by chaining.
 - (ii) When collisions are handled by linear Probing.
 - (iii) When Collisions are handled by double hashing using a second hash function $h'(k) = 10 - (k \text{ mod } 10)$.

- c) Construct an order in which all these tasks shown in the following figure can be completed using topological sort. (12)

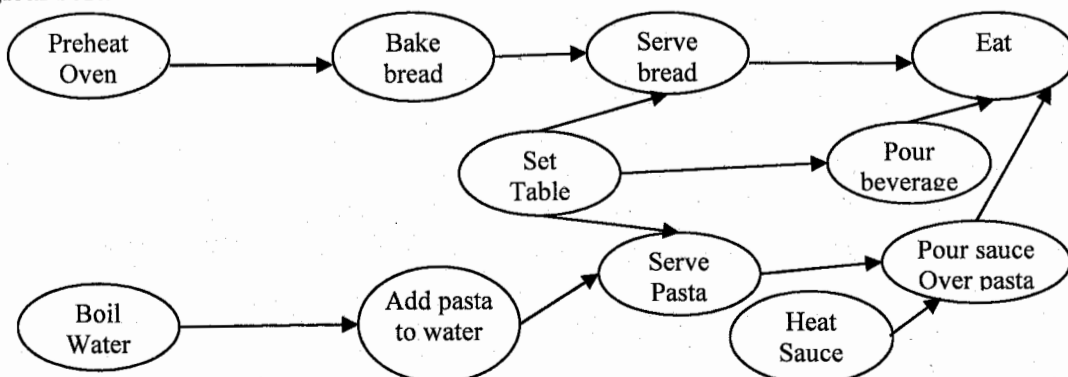

KHULNA UNIVERSITY OF ENGINEERING & TECHNOLOGY
B.Sc. Engineering 2nd Year 1st Term Examination, 2022
Department of Computer Science and Engineering
MATH 2107

Fourier Analysis and Linear Algebra

TIME: 3 hours

FULL MARKS: 210

- N.B. i) Answer **ANY THREE** questions from each section in separate scripts.
ii) Figures in the right margin indicate full marks.

SECTION A

(Answer **ANY THREE** questions from this section in Script A)

1. a) Define integral transform and hence find the kernel of the transform. Also find the kernel of Fourier sine transform. (10)
- b) Define causal and non-causal system with example. (03)
- c) Test whether the following system are causal or not. (12)
 - i) $y(t) = x(t^2)$,
 - ii) $y(t) = x^2(t)$,
 - iii) $y(n) = x(n) - x(n - 1)$.
- d) Write down the important properties of Region of Convergence (ROC) for z-transform. (10)

2. a) Define z-transform. (03)
- b) Find the z-transform of the signal $x(n) = \cos w_0 n u(n)$ and hence using scaling property find the z-transform of $x(n) = 2^n \cos w_0 n u(n)$. (09)
- c) Find $x(n)$ by using convolution for $X(Z) = \frac{1}{(1 - \frac{1}{2}Z^{-1})(1 + \frac{1}{4}Z^{-1})}$. (10)
- d) Find the inverse z-transform of $X(Z) = \frac{Z}{(Z-1)(Z-2)(Z-3)}$ using partial fraction method for ROC $3 > Z > 2$. (13)

3. a) Solve the difference equation $y(k+2) - 18y(k+1) + 32y(k) = 0$ subject to $y(0) = 0, y(1) = 2$ by using z-transform. (13)
- b) Describe the assumptions for the validity of Fourier series expansion. (07)
- c) Obtain Fourier series for the expansion of $f(x) = x \sin x$ in the interval $-\pi < x < \pi$. Hence deduce that $\frac{\pi}{4} = \frac{1}{2} + \frac{1}{1.3} - \frac{1}{3.5} + \frac{1}{5.7} - \dots$ (15)

4. a) Evaluate the Fourier integral of the function $f(x) = e^{-kx}$ when $x > 0$ and $f(-x) = -f(x)$ for $k > 0$. (08)
- b) Determine the Fourier transform of $f(x) = \begin{cases} 1 - x^2, & |x| \leq 1 \\ 0, & |x| > 1 \end{cases}$ (09)
- c) Solve the following boundary value problem by using Fourier transform: (18)

$$\frac{\partial u}{\partial t} = 3 \frac{\partial^2 u}{\partial x^2}, \text{ where } u(0, t) = u(2, t) = 0, t > 0 \text{ and } u(x, 0) = x, 0 < x < 2.$$

SECTION B

(Answer **ANY THREE** questions from this section in Script B)

5. a) Define with example. (12)
 - i) Skew-Hermitian matrix,
 - ii) Orthogonal matrix,
 - iii) Elementary matrix,
 - iv) Upper triangular matrix.
- b) Determine the rank of the matrix A by reducing it to normal form where, (11)

$$A = \begin{bmatrix} 3 & -2 & 0 & -1 \\ 0 & 2 & 2 & 1 \\ 1 & -2 & -3 & 2 \\ 0 & 1 & 2 & 1 \end{bmatrix}$$

- c) Test whether the following matrix is invertible or not. Evaluate the inverse of the following matrix A by applying elementary transformations where, (12)

$$A = \begin{bmatrix} 1 & 2 & -4 \\ -1 & -1 & 5 \\ 2 & 7 & -3 \end{bmatrix}$$

6. a) Define consistent system of linear equations. (03)
 b) Determine the relationship among the constants p , q , and r for which the following system is consistent: (09)

$$\begin{aligned} x + 2y - 3z &= p \\ 3x - y + 2z &= q \\ x - 5y + 8z &= r \end{aligned}$$

- c) If $A = \begin{bmatrix} 2 & 1 & 0 \\ 3 & 2 & 0 \\ 1 & 0 & 1 \end{bmatrix}$, $B = \begin{bmatrix} 1 & 1 & 1 & 0 \\ 2 & 1 & 1 & 0 \\ 3 & 2 & 1 & 2 \end{bmatrix}$. (10)

Compute AB by partitioning.

- d) Investigate the values of λ for which the following system of equations has non-trivial solutions. Solve the system for such values of λ . (13)

$$\begin{aligned} (\lambda - 1)x + (3\lambda + 1)y + 2\lambda z &= 0 \\ (\lambda - 1)x + (4\lambda - 2)y + (\lambda + 3)z &= 0 \\ 2x + (3\lambda + 1)y + 3(\lambda - 1)z &= 0 \end{aligned}$$

7. a) Define vector space and subspace of a vector space with example. (10)
 b) Test whether the following set of vectors forms a basis for \mathbb{R}^3 or not. (10)
 $\{(3, 1, -4), (2, 5, 6), (1, 4, 8)\}$
 c) Construct a basis for the row space, column space and null space of the following matrix. (15)

$$\begin{bmatrix} 2 & 2 & -1 & 0 \\ -1 & -1 & 2 & -3 \\ 1 & 1 & -2 & 0 \\ 0 & 0 & 1 & 1 \end{bmatrix}$$

8. a) Construct bases for the eigenspace of the following matrix A corresponding to the largest eigenvalues of the matrix where, (14)

$$A = \begin{bmatrix} 0 & 0 & -2 \\ 1 & 2 & 1 \\ 1 & 0 & 3 \end{bmatrix}$$

- b) Calculate the angle between A and B with respect to the standard inner product on M_{22} where, (09)

$$A = \begin{bmatrix} 1 & 6 \\ 2 & -3 \end{bmatrix}, B = \begin{bmatrix} 3 & 2 \\ 1 & -4 \end{bmatrix}$$

- c) Apply Gram Schmidt orthogonalization process to transform the basis vectors $v_1 = (1, 1, 1)$, $v_2 = (0, 1, 1)$, $v_3 = (0, 0, 1)$ into an orthogonal basis vectors to obtain an orthonormal basis $\{u_1, u_2, u_3\}$. (12)

TIME: 3 hours

FULL MARKS: 210

- N.B. i) Answer **ANY THREE** questions from each section in separate scripts.
 ii) Figures in the right margin indicate full marks.

SECTION A

(Answer **ANY THREE** questions from this section in Script A)

1. a) Define Computer Architecture. Briefly explain the functional view of a computer and the operations of its component with proper illustrations(s). (13)
 - b) Multiply the following pair of signed 2's complement numbers using the Booth multiplication. Assume that A is multiplicand and B is multiplier ($A = -13$ and $B = -20$). (10)
 - c) Discuss data flow in fetch, indirect and interrupt cycle with proper diagram. (12)
2. a) Consider the state diagram of the following figure: (15)

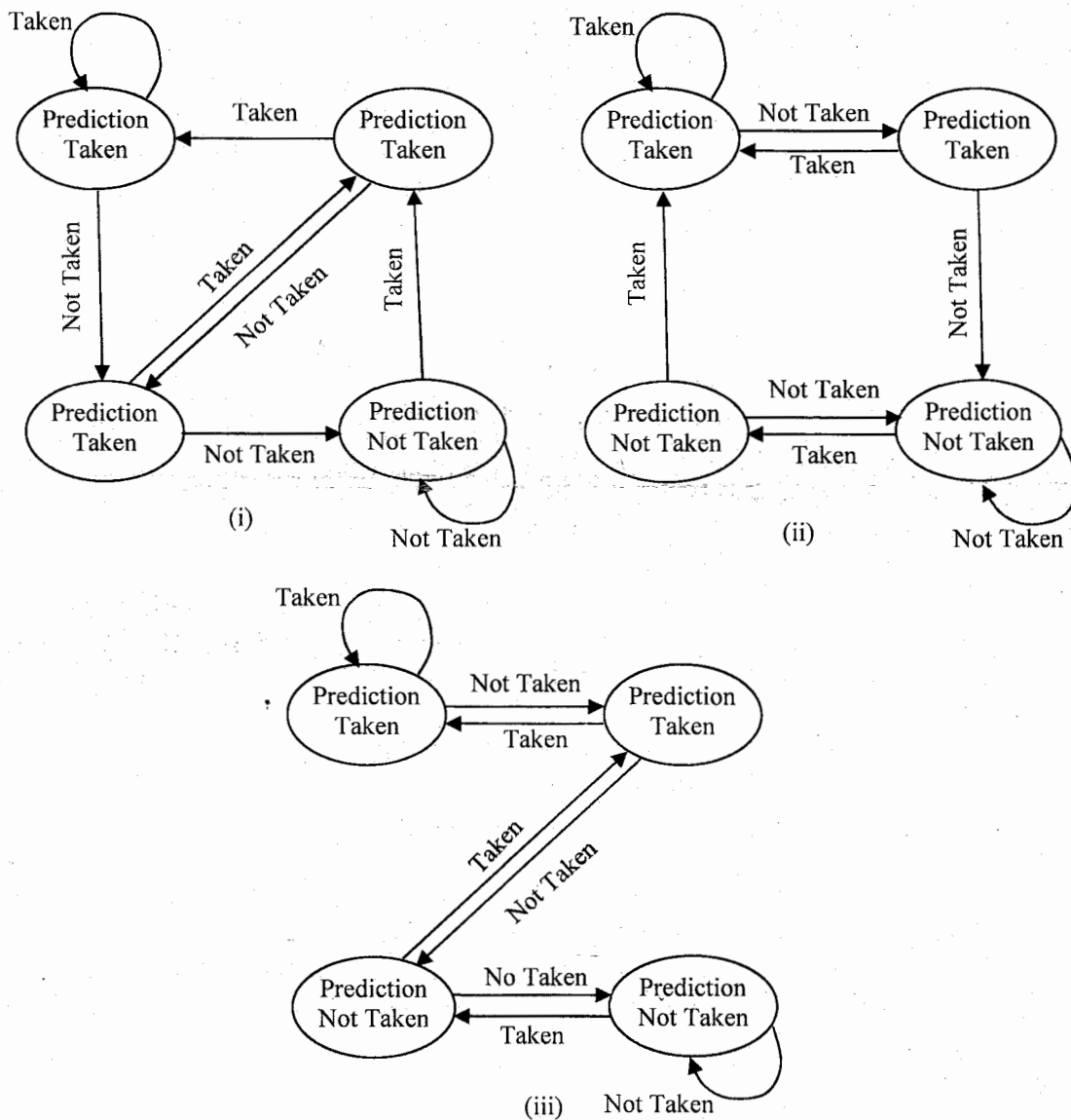

- (i) Describe the behavior of each.
 - (ii) Describe the relative merits of each of the three approaches to branch prediction.
- b) Define overflow. Design an overflow detection circuit by using underlying theory. (10)
 - c) Draw and explain pyramid structure of memory hierarchy. (10)
3. a) Compute $Z = \frac{(A+B-C)}{(C-D) \times E}$, using one, two and three address instructions. (11)
 - b) (i) If the last operation performed on a computer with an 8-bit word was an addition in which two operands were 2 and 3. What would be the value of the following flags? Carry, Zero, Overflow, Sign, Even Parity. (13)
 - (ii) What if the operands were -1 (2's complement) and $+1$?
 - c) Explain instruction set design issues. (11)

4. a) Compare superscalar and super-pipelined approaches with figure and examples. (10)
 b) Briefly explain the instruction pipeline strategy with necessary diagrams. (10)
 c) Define addressing mode. Discuss different addressing modes with their principal advantages and disadvantages. (15)

SECTION B

(Answer ANY THREE questions from this section in Script B)

5. a) Why do you study computer organization and architecture? List the bottlenecks of Von Neumann Architecture. (10)
 b) Virtual memory mechanism bridges the size and speed gap between HDD and RAM-Justify it. (07)
 c) Estimate the relationship between average access time without cache and average access time with cache for 70 % instructions where $h = 0.9$ and 30% data where $h = 0.85$ for interleaved memory. (10)
 d) Illustrate virtual memory address translation process with figure. (08)
6. a) State memory cycle time. Explain Big-Endian and Little-Endian with examples. (10)
 b) Analyze interrupt with short I/O and long I/O with examples. (10)
 c) In a computer system, main memory and cache memory ratio is 64:16 and 20 bits are for addressing. Demonstrate: (15)
 (i) TAG, BLOCK and WORD bits in direct mapping when block size is 32 words.
 (ii) TAG and WORD for associative mapping when block size is 32 words.
 (iii) TAG, SET and WORD bits for set-associative mapping for 4 blocks per set and 32 words per block.
7. a) Describe the types of ROMs. Explain the timing of Disk I/O transfer with figure. (12)
 b) How does RAID3 reconstruct data in the event of drive failure? (10)
 c) The hypothetical machine has the following instructions: (13)

0001 = Load AC from memory
 0010 = Store AC to memory
 0101 = Add AC from memory

Suppose, the value 5 and 3 are stored in memory locations 940 and 941, respectively. Explain program execution with figure to store sum of the two values in the memory location 940. Consider Program Counter (PC). Accumulator (AC) and instruction (IR) for the operation.

8. a) Why do you need DMA? Explain error correction code function with figure. (12)
 b) Consider a disk with an advertised average seek time of 4ms, rotation speed 15000 rpm and 512 bytes sectors with 500 sectors per track. We wish to read a file consisting of 6 tracks. Find total average time for random access. (08)
 c) A 7-bit data 1001010 is passed and written. After that when reading, we use Hamming corrector and before correcting we get 1101010. How do you detect and correct this one-bit error? (15)

KHULNA UNIVERSITY OF ENGINEERING & TECHNOLOGY
 B.Sc. Engineering 2nd Year 1st Term Examination, 2022
 Department of Computer Science and Engineering
 EEE 2113
 Digital Electronics

TIME: 3 hours

FULL MARKS: 210

- N.B. i) Answer **ANY THREE** questions from each section in separate scripts.
 ii) Figures in the right margin indicate full marks.

SECTION A

(Answer **ANY THREE** questions from this section in Script A)

1. a) Define logic families. Illustrate different identical characteristics of a logic family. Briefly explain Noise margin with proper schematic diagram. (10)
- b) Design the following logic functions using CMOS logic. (12)
 - i) $Y = (ABC + DEF)'$
 - ii) $Y = A \oplus B$
 - iii) $Y = ((A + B + C) \cdot D)'$
- c) Connect the output Y of the DTL gate shown in the following figure to N inputs of other similar gates. Assume that the output transistor is saturated and its base current is 0.44 mA. Let $h_{FE} = 20$. (13)

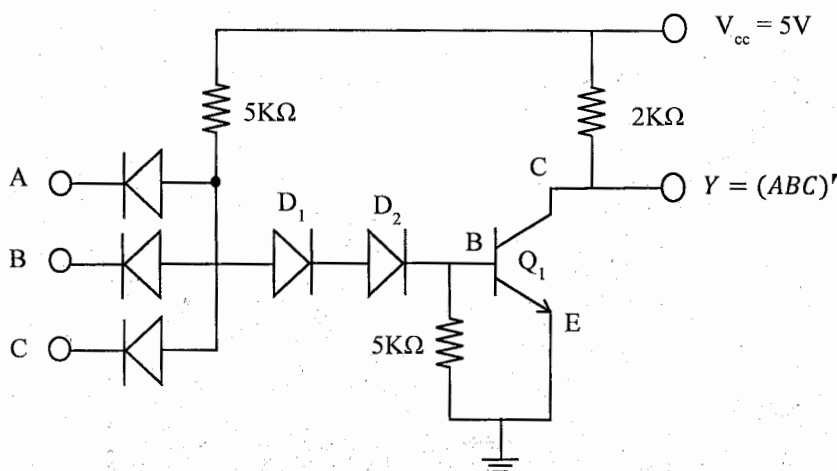

- i) Calculate the current in the 2KΩ resistor.
 - ii) Calculate the current coming from each input connected to the gate.
 - iii) Calculate the total collector current in the output transistor as a function of N.
 - iv) Find the value of N that will keep the transistor in saturation.
 - v) What is the fan-out of the gate?
2. a) What are the functions of Sample and Hold circuit? How an Analog signal is converted into a Digital signal? Explain briefly with neat sketch. (12)
 - b) Draw the circuit diagram of a TTL gate with totem-pole output and explain its superiority over open collector gate. Also write the function of diode of totem-pole configuration. (12)
 - c) Classify TTL logic family based on its output configuration. Show that, "Open collector gate can be tied together to form a common bus." (11)
3. a) Define PLA. Explain PLA based JK FF with truth table, characteristics equation and logic diagram. (11)
 - b) Classify different types of A/D and D/A converters. Draw and write the steps for conversion of 7.1 V into digital signal using successive approximation A/D converter. (12)
 - c) Design a D/A converter for 4-bit digital input in 1's complement format. (12)
4. a) Define and classify PLDs. Also draw the block diagram of CPLD's and FPGA's with their advantages and disadvantages. (12)
 - b) Classify the computer memory system. Write short notes on: (i) ROM, (ii) RAM, (iii) EPROM, (iv) EEPROM, and (v) PROM. (12)
 - c) Draw the circuit diagram of a six-transistor based static Random-Access Memory (RAM) cell. Also draw the diagram of 4 × 4 RAM. (11)

SECTION B

(Answer **ANY THREE** questions from this section in Script B)

5. a) Define wave shaping and duty cycle. For square wave input, examine the output of low pass filter with proper mathematics and figures. (10)

- b) Derive the response of an RC high pass filter for an exponential input $V_i = V(1 - e^{-\frac{t}{\rho_1}})$, (12) where ρ_1 is the time constant.
- c) Differentiate between clipping and clamping circuit. Draw the output waveform of the following circuits for their respective given input. (13)

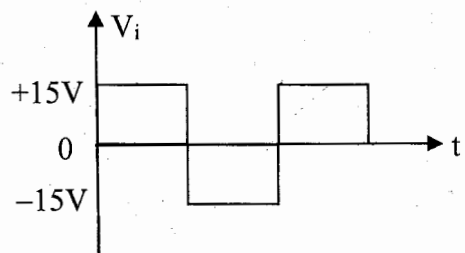

(i)

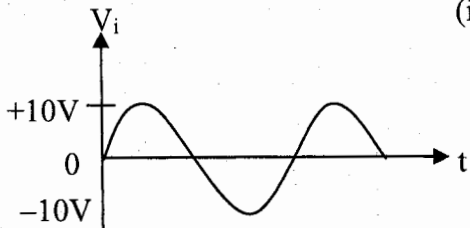
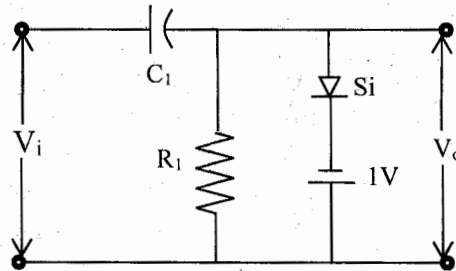

(ii)

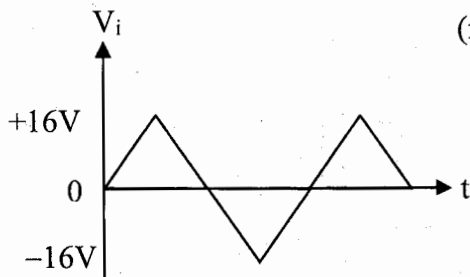
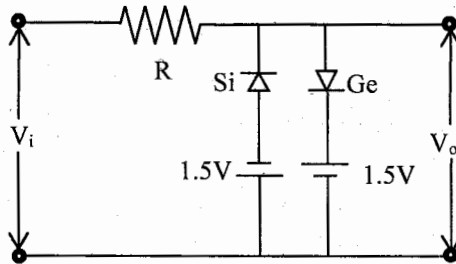

(iii)

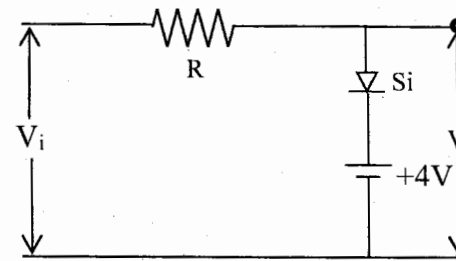

6. a) Define comparator circuit. Explain the operation of a window comparator circuit with necessary diagram. Mention, why it is named as window comparator? (11)
- b) What do you mean by UTP and LTP? Draw the input/output characteristics of Schmitt trigger circuit. (12)
- c) Draw the output waveform for the following clamping circuit. (12)

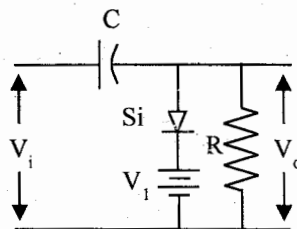
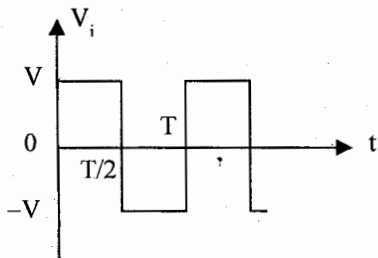

(i)

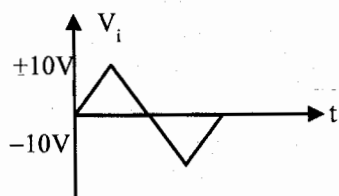
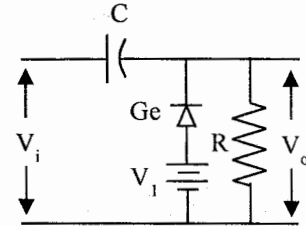

(ii)

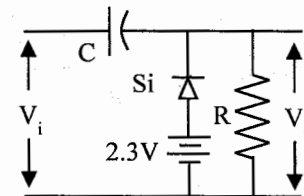

7. a) Define a multivibrator. Classify different types of multivibrator circuits. Draw the input and output waveform (ideal) of different types of multivibrator. (08)
- b) Draw the neat sketch for on-off condition. Derive the expression of frequency and duty cycle of an astable multivibrator for 25% duty cycle with proper circuit diagram. (15)
- c) Consider a linear ramp generator circuit using 555 timer. In this configuration, $V_{CC} = 12V$, $C = 50\mu F$, $R_1 = 10K$, $R_2 = 5K$, $R_E = 100\Omega$, $V_{be} = 0.6V$. Determine the expression of ramp signal and time period, T. (12)
8. a) Write short notes on: (i) DMM, (ii) VTVM, and (iii) Q-meter. (12)
- b) Define pulse transformer. Draw the equivalent circuit of a pulse transformer. Also transform the equivalent circuit to a T network and derive necessary equations. (13)
- c) What is sweep time and restoration time? Design a constant voltage sweep circuit with input and output waveform. (10)