

KHULNA UNIVERSITY OF ENGINEERING & TECHNOLOGY
 B.Sc. Engineering 4th Year 1st Term Examination, 2022
 Department of Computer Science and Engineering
 CSE 4105
 Computer Networks

TIME: 3 hours

FULL MARKS: 210

- N.B. i) Answer **ANY THREE** questions from each section in separate scripts.
 ii) Figures in the right margin indicate full marks.

SECTION A

(Answer **ANY THREE** questions from this section in Script A)

1. a) Define protocol with proper example. Do you think internet standards are necessary for defining computer network protocols? Why or why not? (10)
 b) Let you are a network engineer at XYZ Inc. Your task is to design the forwarding tables of each router in a network. Consider the following network and design the forwarding tables of each router. (15)

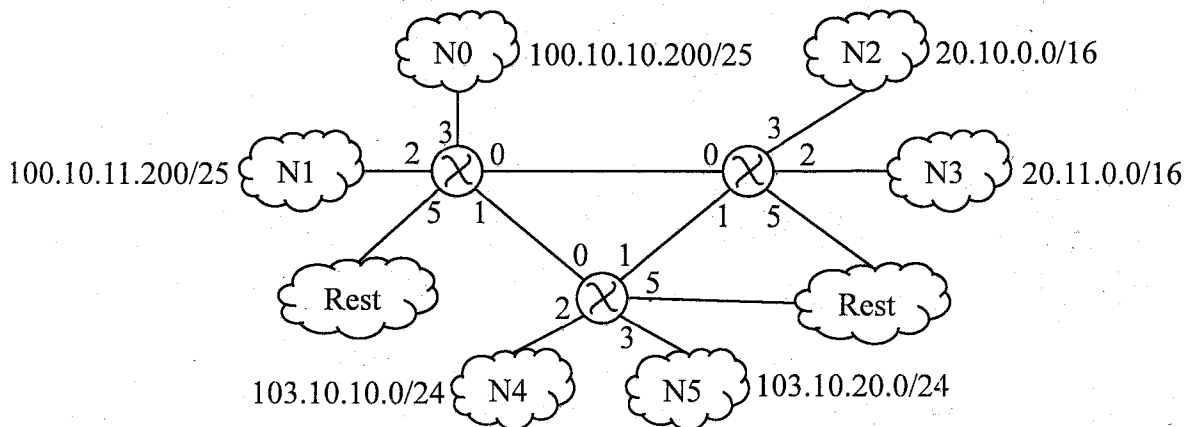

- c) Are there any relations between queuing and switching fabric speed in case of a router? Explain it. (10)
2. a) Define router oscillation problem with proper example. When it occurs? (11)
 b) You are given an IPv4 datagram described in hexadecimal format: "4640 001C 00D1 00B9 1E11 DE0B 4AFA 0A14 C878 321E 0000 000F 0272 6F9A". Answer the following questions based on the given datagram (in decimal). (15)
 i) Header length (in bytes) = ?
 ii) Identifier = ?
 iii) Fragment offset = ?
 iv) Payload = ?
 v) Is it a fragmented packet? If yes, does the packet has any specialty?
 vi) Which fields will get updated if the packet is sent to the next hop router?
- c) How does classless addressing solve the problem with classful addressing? (09)
3. a) Describe the services offered by network layer. Discuss the necessities of IPv6 over Ipv4. (10)
 b) Why does collision occur in CSMA when we only send the packets if the channel sensed idle? Also, demonstrate the collision detection mechanism and algorithm to resolve the issue. (16)
 c) "In BGP, packets are not routed to a specific destination address, but instead to CIDRized prefixes"—justify the statement. (09)
4. a) State how packet filtering firewall works. (06)
 b) Demonstrate how NAT operates. What are the controversial things behind NAT? (09)
 c) Explain how TLS functions. Mention at least one method of obtaining the four keys from the master key. (08)
 d) Let you want to send an email to your friend securely. By ensuring the three most important properties of secure communication, demonstrate the scenario for safeguarding email. (12)

SECTION B

(Answer ANY THREE questions from this section in Script B)

5. a) State the advantages of Peer-to-Peer architecture over Client-Server architecture. Despite those advantages, why do we find Client-Server architecture applied in most of the real life cases? (10)
- b) Should your ISP have its own cache server? Justify your answer. Explain how a cache server acts as both a client and a server. (10)
- c) Say, there is a HTTP client sending 1 byte of data every 5 minutes. Let, 1 HTTP packet contains 1 byte of data. The HTTP server uses the data to update its database in real time. Help the network administrator to choose between persistent and non-persistent HTTP connections. Also, advise him to use or avoid pipelining. Explain your reasonings. (15)

6. a) Does rdt 3.0 use same procedure in case of lost packet and lost acknowledgement? Explain with proper illustrations. (10)
- b) Is SMTP enough to build a complete Email architecture? Justify your answer. (10)
- c) Suppose, a client wants to start an online service. He has five computers ready for this job. These are connected to the internet with IP addresses 212.212.212.101-105. He picked "Network utopia.com" as the domain name for the online service. Your job is to make the service accessible by anyone on the internet. What will be your steps to accomplish that? Explain briefly. (15)

7. a) What are port addresses used for? Is there any constraint on how to assign port addresses or how many of them can be assigned at a time? If yes, then discuss about them. (10)
- b) Suppose a sender and a receiver are using a pipelined protocol, i.e., GBN or SR. In this specific case, the rate at which the sender process pushes data is less than the rate at which the receiver process consumes data. We want to introduce a buffer in the receiving side. Is it a wise decision? Explain the reasoning behind your answer. Also, say, the speed of transport layer at sender side is greater than the sender process pushing data to transport layer. In that case, is there a need for a sender buffer at transport layer? Justify your answer. (13)
- c) Let, a proxy server is used for web caching in case of accessing the URL <http://kuet.ac.bd/cse/home.html>, and the browser of client is configured accordingly. Now, explain the scenario of accessing the web page. (12)

8. a) Differentiate between flow control and congestion control. Explain the necessity of either of those in a reliable data transfer protocol. (10)
- b) In the following figure, some desired packet transfer is shown. Introduce a retransmission timer and then calculate and show Retransmission Timeout time (RTO) where applicable. Let, the initial $RTO = 6$ s.
Recall that, $RTO = RTT_s + 4RTT_D$, where $RTT_D = (1-\beta) RTT_D + \beta |RTT_s - RTT_M|$. Let, the value of α to calculate RTT_s is 0.125 and β is 0.25. (12)

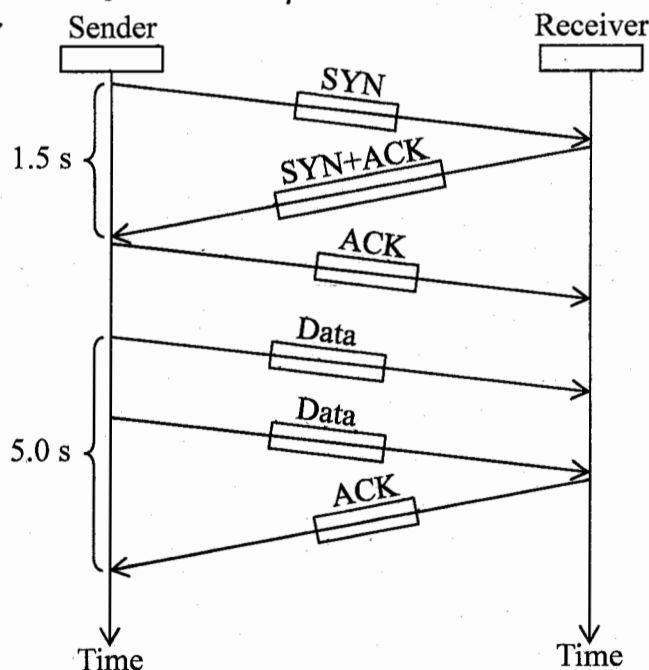

- c) Suppose, in a TCP connection, the receiver process is slow at data consumption. Eventually, the receiver buffer is full and the receiver advertises zero window size. The sender halts sending. Whenever the receiver process consumes a packet, receiver sends an acknowledgement to the sender. Sender sends the next packet. Will this result in a problem? If yes, discuss about the reasoning and a possible solution. (13)

KHULNA UNIVERSITY OF ENGINEERING & TECHNOLOGY
 B.Sc. Engineering 4th Year 1st Term Examination, 2022
 Department of Computer Science and Engineering
 CSE 4109
 Artificial Intelligence

TIME: 3 hours

FULL MARKS: 210

- N.B. i) Answer **ANY THREE** questions from each section in separate scripts.
 ii) Figures in the right margin indicate full marks.

SECTION A

(Answer **ANY THREE** questions from this section in Script A)

1. a) How can you test whether a computer has reached the general intelligence level of human being? Explain. (12)
- b) Consider a cow grazing in a grass field. What are its sensors, actuators, and environment? Explain, how its sensors and actuators are well-suited to its environment. (13)
- c) Is Artificial Intelligence (AI) a science, or is it engineering or neither or both? Explain clearly. (10)

2. a) What is fuzzy logic system? Explain. (10)
- b) Illustrate different operations on fuzzy set. Use pictorial view also. (10)
- c) Design a fuzzy logic-based washing machine system using fuzzy expert system development methodology. (15)

3. a) What is PEAS? Give PEAS description of the task environment for each of the following activities? (10)
 - i) Automated car driving,
 - ii) Playing soccer.
- b) Develop a local search algorithm for solving CSP using min-conflict heuristic. (12)
- c) What is NLP? Explain syntax, semantics, pragmatics and discourse using example(s). (13)

4. a) What is uncertainty? Explain different types of uncertainty using example(s). (10)
- b) Derive the product formula for Bayesian network. Show the steps to calculate the product formula of the following Bayesian network. (12)

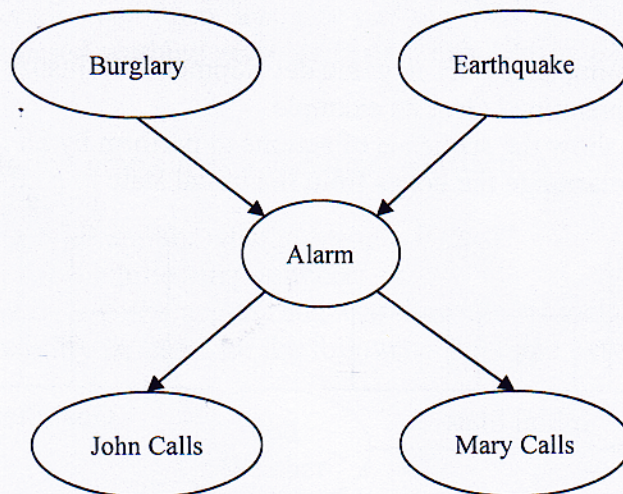

- c) Consider the following Bayesian network. (13)

	Sprinkler	
Rain	F	T
F	0.30	0.70
T	0.03	0.97

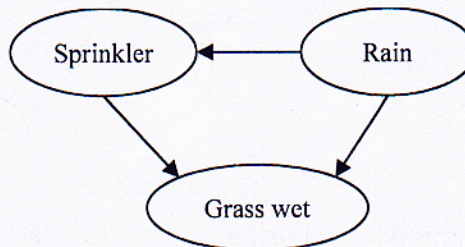

Rain	
T	F
0.30	0.70

Calculate the probability that it is raining given that the grass is wet.

SECTION B

(Answer ANY THREE questions from this section in Script B)

5. a) A machine can replace an expert human. When it will be possible? Illustrate your answer. (10)
 b) Design a generic knowledge-based agent pseudo program. What does it do in each call? (10)
 c) "If the unicorn is mythical, then it is immortal, but if it is not mythical, then it is a mortal mammal. If the unicorn is either immortal or a mammal, then it is horned. The unicorn is magical if it is horned."
 Using propositional logic, can you prove that the unicorn is mythical? How about magical? Horned?

6. a) Verify the following relation between existential and universal quantifier. (07)

$$\forall x P(x) \Leftrightarrow \neg \exists x \neg P(x).$$

- b) Consider the following axioms: (18)
 "Mr. X loves all types of clothes. Suits are clothes. Jackets are clothes. Anything any wear who is not bad is clothes. Mr. Y wears shirt and is good. Mr. Z wears anything Mr. Y wears."
 Convert the above sentences into first order logic and apply forward chaining to prove "Mr. X loves Punjabi."

- c) Differentiate between Greedy best-first search and A* search. (10)

7. a) Consider the Wumpus world problem. The A, W, S, B, G, and P in the grid define the Facts of the Wumpus world. (15)

S		B	P
W	S B G	P	B
S		B	
A	B	P	B

Derive some rules from the Wumpus world problem using the grid and show that there is a Pit (P_{3,3}) in the (3, 3) position.

- b) Define validity, satisfiability, soundness, completeness. (10)

- c) Let, the following two Sentences. (10)
 A = "x = 0", and B = "xy = 0".
 Is there exist any entailment relation between A and B? If yes, then which one is true among $A \models B$ and $B \models A$ or both? Explain.

8. a) Why is Alpha-beta pruning necessary in game development? — justify your answer. (10)
 b) What do you mean by planning? Give an example. (07)
 c) Design the actions and show the sequence of actions to perform by an intelligent agent using goal stack planning to rearrange the boxes from the initial state to goal state. (18)

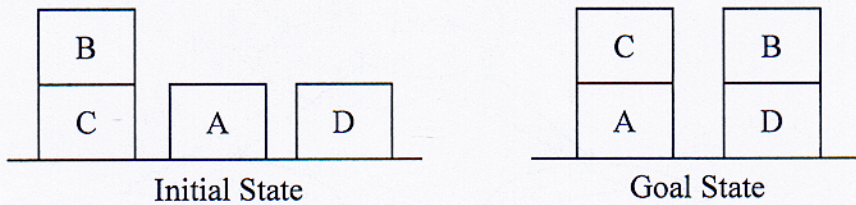

few more / more / planning

0.7	0.0	T	F
0.0	0.0	T	F
0.0	0.0	T	F
0.0	0.0	F	T

KHULNA UNIVERSITY OF ENGINEERING & TECHNOLOGY
 B.Sc. Engineering 4th Year 1st Term Examination, 2022
 Department of Computer Science and Engineering
 CSE 4111
 Machine Learning

TIME: 3 hours

FULL MARKS: 210

- N.B. i) Answer **ANY THREE** questions from each section in separate scripts.
 ii) Figures in the right margin indicate full marks.

SECTION A

(Answer **ANY THREE** questions from this section in Script A)

1. a) Why do we need both an objective function and performance measurement function? Isn't using one of them enough? Justify your answer. (10)
- b) Propose a model to fit the data plotted in the following figure. Discuss about the model's parameters and their effect on the proposed model. For example, the model could be, $f(x) = mx + c$; here m and c are the said parameters. Give an idea about how you can find the optimal values of the parameters. (13)

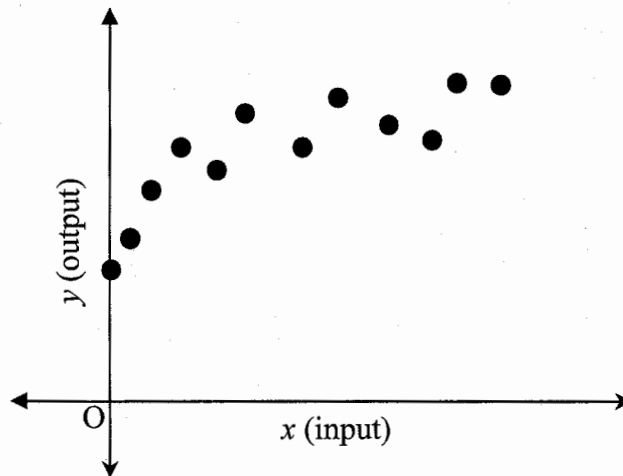

- c) Mr. 'X' developed a machine learning model that performed good on training and validation data but poorly on test data. How do you describe the issue in technical terms? Discuss the possible causes of the issue and some applicable solutions. (12)
2. a) Why gradient descent is so popular among the machine learning community compared to other optimization algorithms? What are the drawbacks of gradient descent? (10)
 - b) What do you mean by overfitting and underfitting? Write down a way to minimize both the issues. (10)
 - c) The following table contains a chunk of data from a big dataset. Considering the given data, what data preparation steps will you take to make it suitable for a machine learning algorithm training task? For demonstrative purpose, apply those steps on the given chunk of data in appropriate order. (15)

Expense	Savings	Eye Color	Height (feet)	Output
5,000	150	Brown	4.2	0
15,000	100	Blue	5.1	1
25,000	200	Brown	5.5	0
10,000	250	Black	4.8	1
12,000	null	Gray	6.2	0
40,000	5000	Black	1005	1

3. a) Differentiate between divisive clustering and agglomerative clustering. (10)
 - b) Suppose you have 1000 data sample of two dimension. You want to divide them among four mutually exclusive clusters as accurately as possible. What clustering algorithm will you choose? Justify your choice. (10)
 - c) Consider that, there is a library consisting of four zones. Each of the zones has five book shelves. Each of the book shelves has six horizontal levels or shelves. You are given a number of books to store in the library. You found out that a single book can be described as a vector of twelve values. You need to keep similar books near each other. Explain your steps to determine the organization of the books in the library. (15)
4. a) Why ensembling is expected to perform better? Explain briefly. How can one make an ensemble of KNN and K-Means algorithms? (10)

b) "A logistic regression is technically a neural network", do you agree with the statement? (10)
 Explain your reasoning. If you agree, then why do we need neural networks other than logistic regressions?

c) The following figure shows a small neural network. Recall the training strategy of a neural network. Let an input sample where, $x_0 = 1, x_1 = 1, x_2 = 0.5$; and output $y = 1$. Calculate and show the updated weights for a single iteration. For your convenience,

$$\frac{\partial L}{\partial \hat{y}} = -\left(\frac{y}{\hat{y}} + \frac{y-1}{1-\hat{y}}\right); \frac{\partial \delta(z)}{\partial z} = z(1-z); \frac{\partial ReLU(z)}{\partial z} = \begin{cases} 0 & \text{for } z < 0 \\ 1 & \text{for } z \geq 0 \end{cases}$$

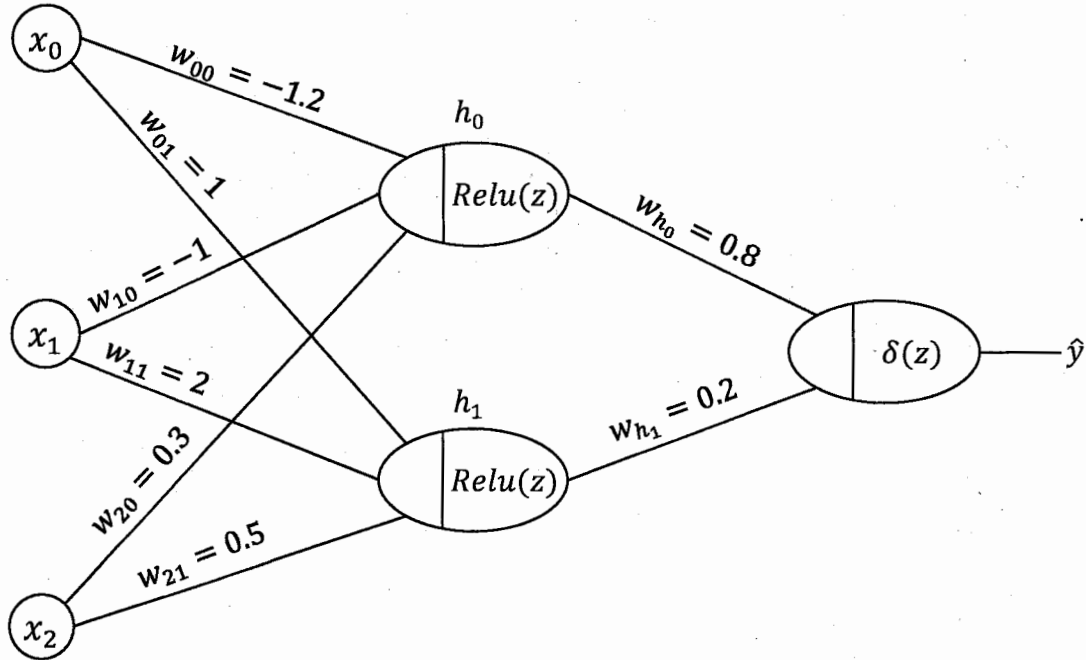

SECTION B

(Answer ANY THREE questions from this section in Script B)

5. a) "Crossover is explorative and Mutation is exploitative"—justify the statement with respect to GA. (08)

b) Suppose two TSP solutions are 4 – 9 – 6 – 3 – 1 – 8 – 2 – 5 – 7 and 6 – 1 – 2 – 7 – 5 – 9 – 8 – 3 – 4 where numeric values are city indexes. Generate an offspring from the solutions using Enhanced Edge Recombination algorithm. (10)

c) Use GA to solve the following optimization problem: (17)

$$\text{Maximise: } 340x - 10x^3 \text{ for } 0 \leq x \leq 31$$

Perform one iteration of the algorithm with the following four strings as the original populations: $S_1: 11011, S_2: 01010, S_3: 01000, S_4: 10101$.

6. a) Briefly explain the curse of dimensionality problem. (07)

b) Consider the following dataset with 2 dimensions: (20)

x_1	4.5	2	2.5	4	3.5	4.5	3	4	5	3
x_2	3	1.5	2	3	2.5	4	2	3.5	4	2.5

Using Principal Component Analysis (PCA), reduce the dataset to one dimension. Explain each step with necessary calculations.

c) How can SVM classify non-linear separable data? Explain with an example and proper figure. (08)

7. a) Why pre-pruning and post-pruning are necessary for decision trees? How does error propagate in decision trees? (09)

b) Consider the following table where "Buys_computer" represents class label. Find root attribute of the Decision Tree using Gini Index as the attribute selection measure. (16)

Age	Income	Student	Credit rating	Buys_computer
youth	high	no	fair	no
youth	high	no	excellent	no
middle age	high	no	fair	yes
senior	medium	no	excellent	yes
senior	low	yes	excellent	yes
senior	low	yes	fair	no
middle age	low	yes	fair	yes
youth	medium	no	fair	no
youth	low	no	excellent	yes
senior	medium	yes	fair	yes
youth	medium	yes	excellent	no

- c) "Pheromone evaporation pushes ACO convergence"—is it true? Justify your opinion. (10)
8. a) Find the minimum of the function $f(x_1, x_2) = 100(x_2 - x_1)^2 + (1 - x_1)^2$ in the range $-5 \leq x_1, x_2 \leq 5$ using the PSO method (initial values are given in following table). (15)

Initial swarm				
p_i	x_1	x_2	v_1	v_2
p_1	2.212	3.009	0.0	0.0
p_2	-2.289	-2.396	0.0	0.0
p_3	-2.393	-4.790	0.0	0.0
p_4	-0.639	1.692	0.0	0.0

$N = 4$
$t = 2$
$w = 0.75$
$c_1 = 1.5$
$c_2 = 2.0$

- b) Explain the fundamental differences between ACO and PSO to establish interaction among individuals. (05)
- c) Consider the problem of ACO to look for a solution to TSP for 5 cities. The symmetric travel costs for cities {1, 2, 3, 4, 5} are given in the matrix C . The start city is City1. At time t , the pheromone deposits between cities are summarized in matrix P . (15)

$$C = \begin{pmatrix} 0 & 27 & 23 & 10 & 70 \\ & 0 & 20 & 10 & 16 \\ & & 0 & 5 & 10 \\ & & & 0 & 20 \\ & & & & 0 \end{pmatrix} \quad P = \begin{pmatrix} \times & 1 & 2 & 3 & 2 \\ & \times & 7 & 2 & 0 \\ & & \times & 3 & 1 \\ & & & \times & 5 \\ & & & & \times \end{pmatrix}$$

- (i) At time t , Ant1 has moved from City1 to City3. Perform all probability calculations needed to determine which city Ant1 will move to next if the decision is to be made by pheromone only.
- (ii) Repeat (i) when the decision is based on both pheromones and cost with equal weights.

KHULNA UNIVERSITY OF ENGINEERING & TECHNOLOGY
B.Sc. Engineering 4th Year 1st Term Examination, 2022
Department of Computer Science and Engineering
CSE 4115

Computer and Network Security

TIME: 3 hours

FULL MARKS: 210

- N.B. i) Answer **ANY THREE** questions from each section in separate scripts.
ii) Figures in the right margin indicate full marks.

SECTION A

(Answer **ANY THREE** questions from this section in Script A)

1. a) Suppose to withdraw money from your Bank account when you put a signature over your Bank cheque, what are the properties essential to retain concerning it? Explain them. Now, analyze that RSA algorithm is capable to fulfill those properties or not. Establish your intuition relating the specific portion of RSA algorithm. (13)
- b) Differentiate between 'Cryptography' and 'Cryptanalysis'. Justify them, i.e., how they are associated with Caesar cipher technique. (10)
- c) List the trends in case of any good cipher. Analyze relevancy of 'Known-Plaintext-Attack' with RSA encryption algorithm. (12)
2. a) Discuss major goals (i.e., CIA) of security. Using a diagram state and explain ingredients of a cryptosystem. (09)
- b) Explain properties of cryptographic hash function. How and why data encryption and hash techniques need to perform concurrently? Propose an outcome from your thinking. (11)
- c) Discuss pros and cons of 'Stream cipher' and 'block cipher'. Assess the working procedures of Caesar cipher, RSA cipher, Vernam cipher etc., with block and Stream ciphers. (15)
3. a) Relating order, prime and primitive element, demonstrate a bonding. Also, judge your bonding for a prime 13, and order 2. (08)
- b) Explain how triple DES performs data encryption. Using a block diagram illustrate the major steps of each cycle of AES algorithm. (11)
- c) Discuss characteristics maintained by "Good Viruses". (06)
- d) Considering two messages m_1 and m_2 , develop a model of ElGamal product cipher. Also demonstrate the decryption technique. Step wise write the whole procedure. (10)
4. a) Design a procedure to develop data encryption and digital signature for RSA algorithm together. (08)
- b) "ElGamal digital signature is based on discrete logarithm"—how discrete logarithm manages key generation, signing, verification, etc.? Explain. (11)
- c) How ElGamal cipher can be modified to re-randomize itself? Explain. (07)
- d) Discuss various aspects that make computer networks vulnerable. (09)

SECTION B

(Answer **ANY THREE** questions from this section in Script B)

5. a) Explain relocation of address with example. What are the complementary goals to protect object of OS? (09)
- b) Discuss how ECC works based on the basic of trapdoor function. (10)
- c) Explain the types of Salami attack. What are the impacts and preventions of DHCP spoofing attack? (10)
- d) Differentiate among black hat, white hat and grey hat hackers. (06)
6. a) What is polymorphic virus? How does an Email impersonation attack work? (08)
- b) What are the considerations before committing to a hybrid firewall solution? Let, a businessman works with a public website, accessible from the internet, which put the entire internal network at high risk. Explain which network can help him to conduct his business securely and how? (15)
- c) Explain with figure how paged segmentation removes the problems associated with segmentation and paging. (12)

7. a) Discuss the problems created by format string attack and countermeasures for them. (15)
- b) Demonstrate the ways to keep devices safe from wiretapping. (12)
- c) Which one is preferable, RSA or, ECC? Explain why? (08)

8. a) Suppose an attacker may introduce extra code, sending new instructions to the application to gain access to IT systems. If attackers know the memory layout of a program, they can intentionally overwrite the executable code with their own code. What kind of attack is this? What are the countermeasures for it? (15)
- b) Explain how documents virus works in Microsoft's excel Microsoft's word file using DDE protocol. (10)
- c) What are the responsibilities of firewall administrators? What are the challenges of intrusion detection system? (10)

KHULNA UNIVERSITY OF ENGINEERING & TECHNOLOGY
 B.Sc. Engineering 4th Year 1st Term Examination, 2022
 Department of Computer Science and Engineering
 CSE 4127

Image Processing and Computer Vision

TIME: 3 hours

FULL MARKS: 210

- N.B. i) Answer **ANY THREE** questions from each section in separate scripts.
 ii) Figures in the right margin indicate full marks.

SECTION A

(Answer **ANY THREE** questions from this section in Script A)

1. a) Construct a modified image using histogram specification. The histograms of original and (20)
 target images are given below.

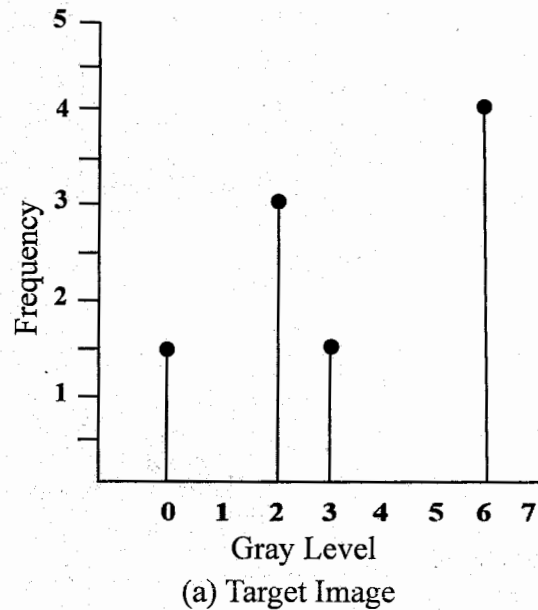
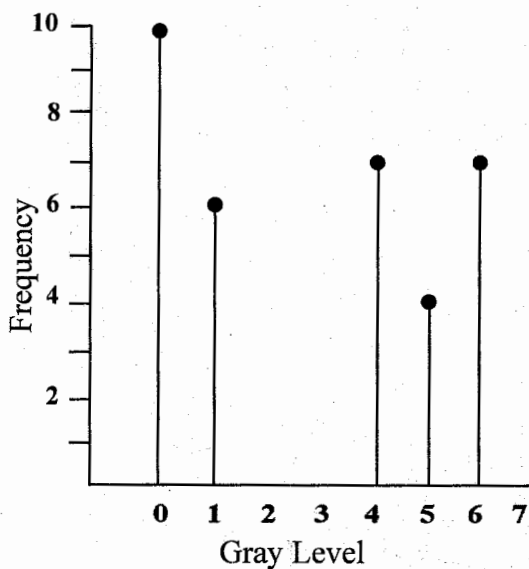

- b) Use 8-connectivity and m -connectivity to find the shortest path between pixels (1, 1) with (10)
 value 10 and (8, 8) with value 100, if $V = \{0, 10, 50, 65, 100, 106\}$.

10	55	60	65	05
106	65	56	102	200
112	0	50	50	150
30	45	65	60	120
45	106	10	65	100

- c) Let, you have computed the 2D DFT of a given image. The magnitude spectrum ranges from (05)
 0 to 10^5 , but you want to display the image as an 8-bit gray scale image. For this purpose, you
 apply base-10 log transformation to the spectrum. What must be the normalizing constant of
 the transformation?

2. a) Following is a 5×5 image with 5 distinct gray levels: (25)

18	18	4	12	12
10	10	4	12	4
10	4	12	4	15
12	10	15	15	10
15	12	4	10	4

Compare the efficiency of compressing the image using Huffman encoding and Golomb
 coding with parameter, $m = 5$.

- b) Explain why transformation function to perform image complement approximation is different (10)
 for each component in HSI model but similar for all components in RGB model.
3. a) Consider a line of intensity values, $\{100, 129, 145, 56, 99\}$ If it is quantized with 4 higher bit (08)
 planes, compute the error and signal-to-noise ratios for the quantized data.

- b) Explain which type of histogram equalization would perform better visual improvement for the following image. (12)

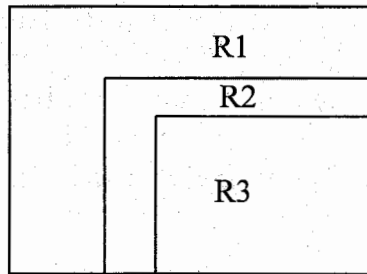

Pixel values of region,
 R1 = 127,
 R2 = 129,
 R3 = 130.

- c) Figure below shows a binary image containing Greek letter θ , and four structuring elements. (15)
 What morphological operations(s) would you use to obtain the number zero (0) from the letter θ ? Consider that you can use any of the given structuring elements as many times as you wish. Provide a reason for your choice of operation(s) as well as the structuring elements.

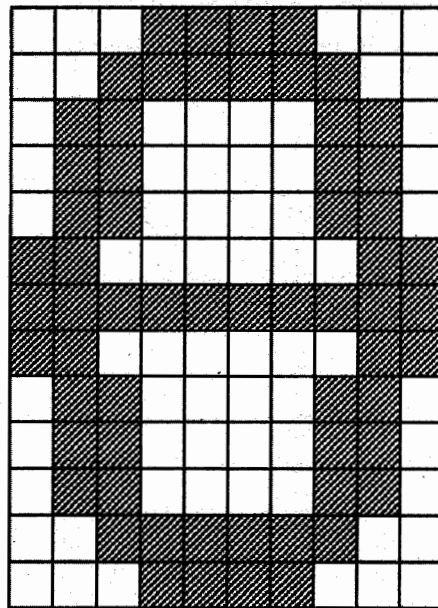

Binary image

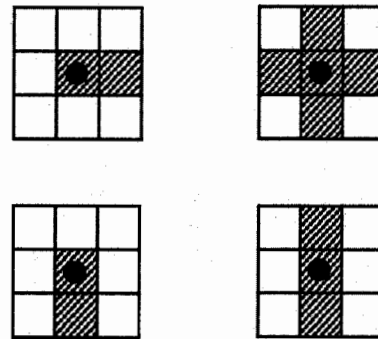

Structuring elements

4. a) Sketch the result of the following operations: (10)
 $D_G^{(n)}(F)$ where F is marker and G is mask image. Use structuring element of 3×3 with all 1's.

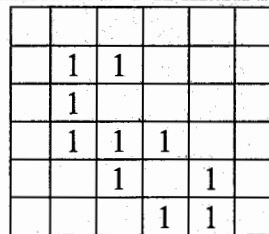

Mask G

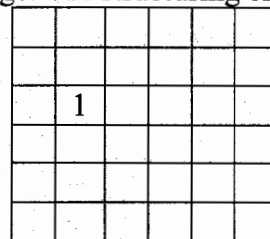

Marker F

- b) Use necessary diagrams to show the conceptual relationship between the RGB and HSI color models. (12)
 c) Explain with necessary mathematical formulation, how you can apply a linear filter on a color image represented in HSV color space. Also mention the need of saturation weighted hue component. (13)

SECTION B

(Answer ANY THREE questions from this section in Script B)

5. a) State the property of a linear operation. With necessary mathematical formulation, show that convolution is a linear operation. (10)
 b) You are given the following spatial domain filter. (15)

0.15	0.35	0	-0.35	-0.15
------	------	---	-------	-------

- i) Compute Fourier spectrum and phase of this filter,
 ii) What do you think the effect of applying this filter to an image will be? Justify your answer.
 c) Construct a homomorphic filtering function using a Butterworth high pass filter to correct nonuniform illumination. (10)

6. a) Consider the image histogram given below. (18)

Intensity level	0	1	2	3	4	5
Frequency	14	11	4	12	16	7

Use maximum entropy-based thresholding technique to find a global threshold to segment the image.

- b) State the necessity of non-maximum suppression stage used in Canny edge detection algorithm. Provide an idea to get edge orientation by avoiding trigonometric function that can be used in the Canny's algorithm. (12)
- c) "Median filter may reduce the number of occupied bins in a histogram." – justify the statement. (05)
7. a) A 100×100 image is warped applying the following affine transformation matrix T. Mention the warped image size. Let, you are currently at pixel (50, 65) in the warped image, find its intensity if inverse mapping technique and bilinear interpolation were used during warping. Consider the following image segment of the input image. (16)

$$T = \begin{bmatrix} 1 & 0.6 & 5 \\ 1.2 & 0.8 & 10 \\ 0 & 0 & 1 \end{bmatrix}$$

$y \backslash x$	36	37	38	39
10	60	65	70	72
11	66	70	80	88
12	80	90	95	120
13	90	92	110	150

image segment

- b) Segment the following image using spit and merged procedure. (12)

	1	1	1	1	1
	1	1	1	1	1
	1			1	1
	1			1	1

- c) Explain aperture problem in optical flow estimation. (07)

8. a) Let you are going to restore a noisy image having only additive noise. For the restoration purpose you construct the following histogram of a flat region of the image. (12)

Intensity level	0	1	2	3	4	5	6	7
Probability	0	0	0.210	0.404	0.277	0.102	0.022	0.003

- i) Determine the type of noise present,
 ii) Provide an estimation of the parameters: mean and standard deviation of the noise density function.
- b) Find the region descriptors: form factor, compactness, and circularity to describe the binary region in the following images. (12)

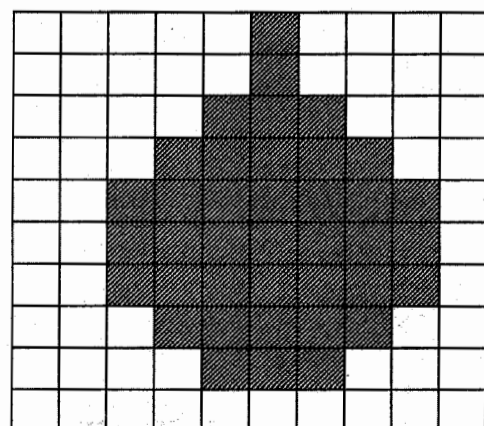
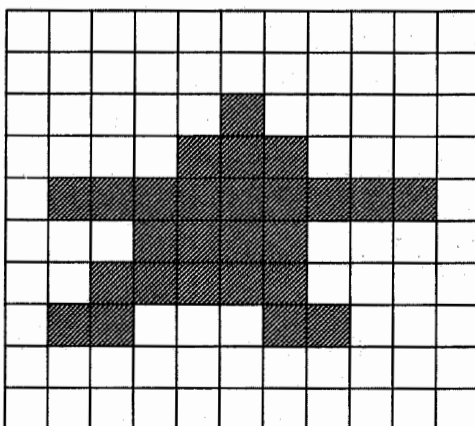

- c) Derive the brightness consistency equation to estimate motion field as a form of optical flow. Suggest an idea to overcome its limitation. (11)

KHULNA UNIVERSITY OF ENGINEERING & TECHNOLOGY
 B.Sc. Engineering 4th Year 1st Term Examination, 2022
 Department of Computer Science and Engineering
 IEM 4127
 Industrial Management

TIME: 3 hours

FULL MARKS: 210

- N.B. i) Answer **ANY THREE** questions from each section in separate scripts.
 ii) Figures in the right margin indicate full marks.

SECTION A

(Answer **ANY THREE** questions from this section in Script A)

1. a) Define industrial management. Relate why a CSE student needs to study industrial management. (10)
- b) The newly joined MTO of company A believes that management is a static process and he measures his performance with respect to that belief. Criticize the belief of the newly joined MTO. (12)
- c) Company A is now thinking of recruiting a new manager who can improve both the employee and industry performances. Demonstrate the managerial skills that a HR need to find in new manager. (13)

2. a) Company B thinks that delegation of work can improve the performance of employee. Identify the objectives and advantages of delegation. (10)
- b) The staffs of company B wants to arrange a fest. But one group wants to follow “Scientific management theory” for taking ideas where others want to follow “management process theory.” After thoroughly reviewing both process components and functions, recommend one to them, (12)
- c) Company B recently finds out that the primary functional department(line people) can perform well if they get specialized advice. But specialized department also needs help from line executives. Develop and discuss about an organizational structure that can help company B. (13)

3. a) Compare between democratic and authoritarian leadership. (08)
- b) Ms. X wants to become a manager. But during her interview the recruiter told that, “We are not looking for manager, we are looking for a leader.” Interpret this statement by differentiating between manager and leader. (12)
- c) A conflict has been taken place between the worker council and owner of C1 company about incentive plans. They find out that their company offers them 20-taka hourly wages rate and their standard work time is 12 hours. They entitled for 50% bonus if their work completion time become 67% of their standard work time. Whereas, their neighbor company C2 offers the same wage rate, same condition for time standards and completion time. Still, C2 workers get higher wages incentives than C1. How is this possible? Find both company’s incentive and wages distribution strategy mathematically. (15)

4. a) See the following two figures. Predict which Breakeven Point (BEP) will be more lucrative to company owner and why? (10)

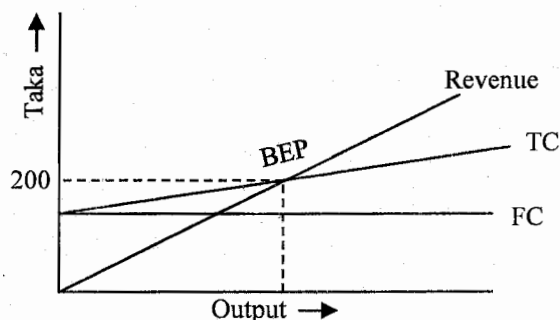
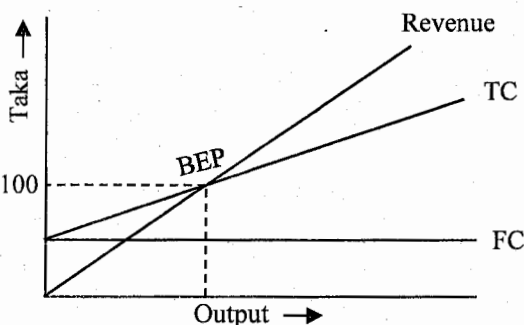

- b) Company D is going to manufacture a new mobile. The estimate that the fixed cost associated with manufacturing will be 400,000 taka per year. If base unit sells for 1,475 taka and its variable cost is 1,037.5 taka, then: (12)
 - i) Quantify the number of units must be sold each year for breakeven, and
 - ii) What will the profit be for sales of 3,000 units per year?
- c) Exactly 10 years ago, company D professional associates purchased \$100,000 in depreciable assets with an estimated salvage of \$10,000. For tax depreciation, the SL method with $n = 10$ years was used. But for book depreciation company D applied the DDB method with $n = 7$ years and neglected the salvage estimates. The company sold the asset today for \$12,500. (13)
 - i) Compare the sells price today with the book values using the SL and DDB methods.
 - ii) If the salvage of \$12,500 had been estimated exactly 10 years ago, determine the depreciation for each method in year 10.

SECTION B

(Answer ANY THREE questions from this section in Script B)

5. a) Define forecasting. Compare the main advantages that quantitative techniques for forecasting have over qualitative techniques. (10)
- b) A manager uses this equation to predict demand for landscaping services: $F_t = 10 + 5t$. Over the past eight periods, demand has been as follows: (13)

Period, t	1	2	3	4	5	6	7	8
Demand	15	21	23	30	32	38	42	47

Evaluate whether the forecast is performing adequately or not.

- c) Show that the economic run quantity in EPQ model $Q_p = \sqrt{\frac{2DS}{H}} \sqrt{\frac{P}{P-U}}$, where the symbols have their usual meanings. (12)
6. a) A firm that produces wood shutters and bookcases has received two orders for shutters: one for 100 shutters and one for 150 shutters. The 100-unit order is due for delivery at the start of week 4 of the current schedule, and the 150-unit order is due for delivery at the start of week 8. Each shutter consists of two frames and four slatted wood sections. The wood sections are made by the firm, and fabrication takes one week. The frames are ordered, and lead time is two weeks. Assembly of the shutters requires one week. There is a scheduled receipt of 50 wood sections in (i.e., at the beginning of) week 1. (15)
- i) Draw a product structure tree for the given problem,
- ii) Determine the size and timing of planned order releases necessary to meet delivery requirements for Lot-size ordering with a lot-size of 270 units for frames and 60 units for wood sections.
- b) Define scheduling. Differentiate between PERT and CPM. (08)
- c) A jewelry firm buys semiprecious stones to make bracelet and rings. The supplier quotes a price of \$8 per stone for quantities of 600 stones or more, \$9 per stone for orders of 400 to 599 stones, and \$10 per stone for lesser quantities. The jewelry firm operates 200 days per year. The usage rate is 25 stones per day, and ordering costs are \$48. (12)
- i) If annual carrying costs are 30 percent of unit cost, what is the optimal order size?
- ii) Determine the ordering frequency.
- iii) If the lead time is six working days, at what point the company should reorder?
7. a) Define the following terms: (i) MRP, (ii) Bill of materials, (iii) Tracking signal, and (iv) RoP. (10)
- b) Define dummy activity. Develop an assignment plan that will minimize processing costs, given the information shown, and interpret your answer. (13)

		Worker		
		A	B	C
	1	12	8	11
	2	13	10	8
Job	3	14	9	14
	4	10	7	12

- c) The following table contains information related to the major activities of research project. (12)

Activity	Immediate Predecessor	Expected time (Days)
a	—	4
b	—	2
c	a	5
d	a	4
e	c, b	6
f	c, b	1
g	d, e	6

Use the information to do the followings:

- i) Draw a precedence diagram using AON,
- ii) Determine the critical path,
- iii) Determine the amount of slack time for each path.
8. a) Define maintenance. Distinguish between corrective maintenance and breakdown maintenance. (08)
- b) Explain the Brown-Gibson approach for evaluating locations with the help of a flowchart. (12)
- c) List the assumptions of priority rules for scheduling jobs. (05)
- d) Construct a project life cycle. Provide a brief overview of the purpose and significance of each phase in ensuring project success. (10)