

KHULNA UNIVERSITY OF ENGINEERING & TECHNOLOGY  
 B.Sc. Engineering 4<sup>th</sup> Year 1<sup>st</sup> Term Examination, 2023  
 Department of Computer Science and Engineering  
 CSE 4105  
 Computer Networks

TIME: 3 hours

FULL MARKS: 210

- N.B. i) Answer **ANY THREE** questions from each section in separate scripts.  
 ii) Figures in the immediate right column of the questions indicate full marks.  
 iii) The rightmost column indicates the course outcomes.

**SECTION A**

(Answer **ANY THREE** questions from this section in Script A)

1. a) Explain the purpose of OSI model. Do all devices present in a network implement all (10) [CO1] OSI layers? Justify your answer.
- b) In the network shown in following figure, the server 223.1.2.5 receives an IP packet with (12) [CO2] src: 0.0.0.0, 68 and dest: 255.255.255.255, 67. What would happen next? Complete the interaction.
- c) Explain the benefits of Port-based VLANs. Explain the process and switch table to (13) [CO3] transmit a frame from port 2 of switch 1 to port 4 of switch 2, shown in following figure.

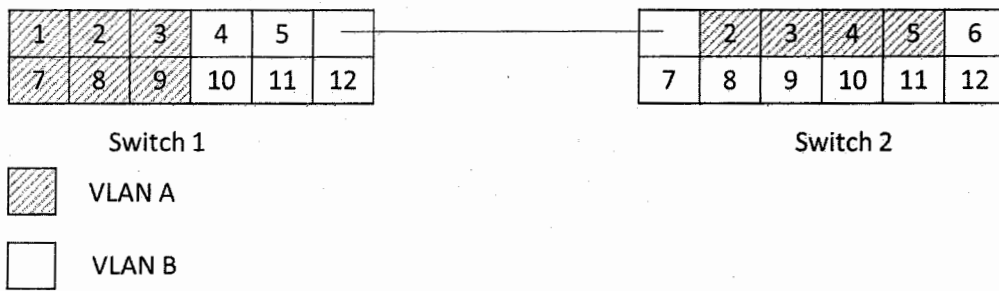

2. a) Consider the following 20-byte header (IPv4). Find the header checksum. Why does (10) [CO1] IPv4 header checksum cover only data portion?

4	5	0	28
1		0	0
4	17	0	
10.12.14.5			
12.6.7.9			

- b) Explain the hot potato routing protocol. Briefly explain the benefits and drawbacks of (12) [CO3] this protocol.
- c) Using a Link-State routing algorithm, determine the routing table at the router X from (13) [CO2] the topology given in following figure.

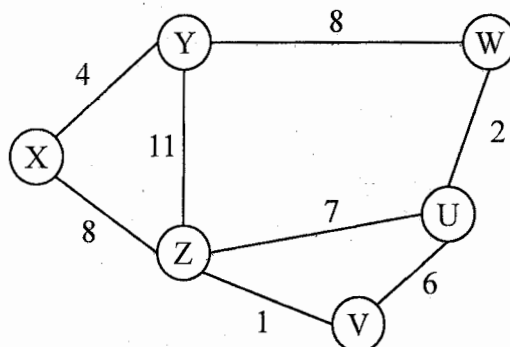

3. a) An ISP is granted a block of addresses starting with 190.100.0.0/16. The ISP needs to (13) [CO2] distribute these addresses to 3 group of customers:
  - i) 1<sup>st</sup> group: 52 customers, each needs 128 addresses.
  - ii) 2<sup>nd</sup> group: 40 customers, each needs 256 addresses.
  - iii) 3<sup>rd</sup> group: 100 customers, each needs 64 addresses.

How many addresses are still unallocated? Note down the network addressed of each group.

- b) Suppose you have a broadcast channel in Ethernet CSMA/CD algorithm with (10) [CO3] transmission rate 10 Mbps where a node can transmit a frame of max 1500 bytes, and maximum propagation delay between 2 nodes is: 2ms.
- Calculate the efficiency of the algorithm.
  - When would it reach its highest efficiency, and why?
- c) In the switch shown in following figure, all datagrams have the same fixed length and (12) [CO1] the switch operates in a slotted, synchronous manner. Assuming a datagram can be transferred from input port to output port in one time slot, what is the minimal number of slots needed for the transfer of all datagrams when:
- The switching fabric is memory.
  - The switching fabric is bus.
  - The switching fabric is crossbar.
- Briefly explain the process for each of these switching fabrics (You can assume any input queue scheduling order).

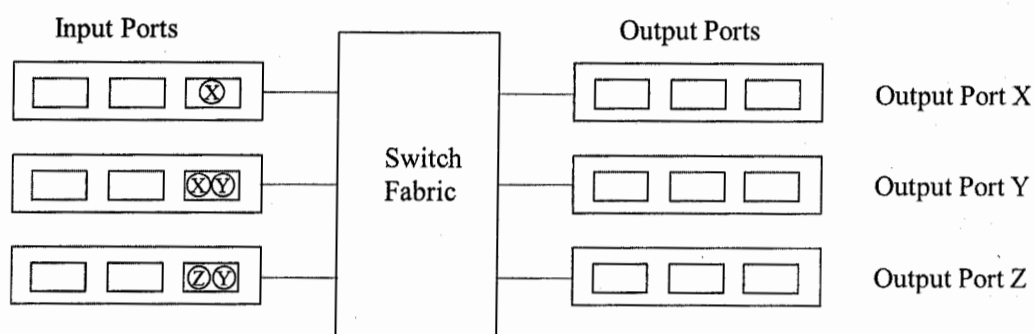

4. a) Define SDN control plane. Briefly explain the characteristics of SDN. (10) [CO1]
- b) State router oscillation problem with proper example. When it occurs? (10) [CO3]
- c) In the network shown in following figure, a data packet is routing from A to C and C (15) [CO2] sends a response to A. Assuming all hosts know the necessary IP addresses, MAC addresses and first hop router addresses, show the data capsulation and decapsulation in each device with necessary diagram(s) and table(s).

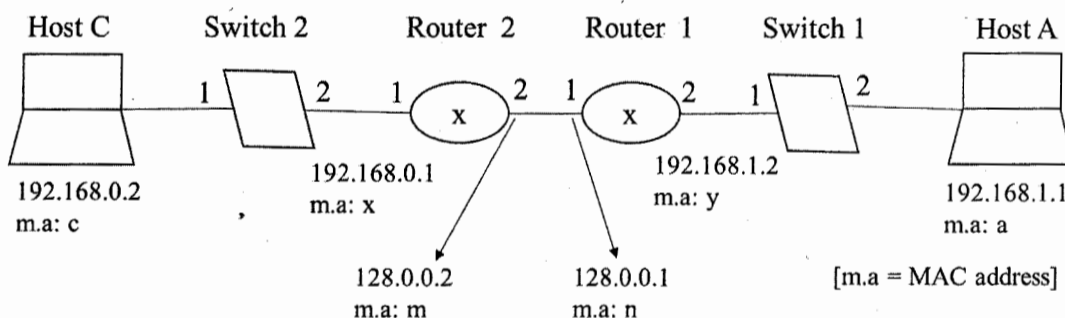

### SECTION B

(Answer ANY THREE questions from this section in Script B)

5. a) List down the steps involved in SSL handshaking. Also, present a pictorial view of (10) [CO2] packet transmission.
- b) Is SMTP enough to build a complete Email architecture? Justify your answer. (10) [CO2]
- c) Suppose a sender and receiver are using a pipelined protocol, i.e., Go Back-N or (05) [CO3] Selective Repeat. In this specific case, the rate at which the sender process pushes data is less than the rate at which then sender consumes data. We want to introduce a buffer in the receiving side. Is it a wise decision? Explain the reasoning behind your answer.
- d) Let, host at *abc.poly.edu* wants IP address for *defg.cs.uxyz.edu*. Explain the procedure (10) [CO2] of getting IP address using recursive queries for various DNS servers.
6. a) State the advantage of P2P over client-server architecture. Despite those disadvantages, (10) [CO1] why do we find Client-server architecture applied in most of the real-life cases?
- b) Consider the following figure where Mr. X wants to access a webpage hosted on a (15) [CO2] Google server. This webpage comprises a base HTML file along with 10 JPEG images, each with a length of 1024 bits. The transmission rate of the link connecting Mr. X to the server is 1 Mbps. Determine the total response time for both Non-persistent and persistent HTTP by real internet delay. Mr. X measures real internet delay by traceroute program.



KHULNA UNIVERSITY OF ENGINEERING & TECHNOLOGY  
 B.Sc. Engineering 4<sup>th</sup> Year 1<sup>st</sup> Term Examination, 2023  
 Department of Computer Science and Engineering  
 CSE 4109  
 Artificial Intelligence

TIME: 3 hours

FULL MARKS: 210

- N.B. i) Answer **ANY THREE** questions from each section in separate scripts.  
 ii) Figures in the immediate right column of the questions indicate full marks.  
 iii) The rightmost column indicates the course outcomes.

**SECTION A**

(Answer **ANY THREE** questions from this section in Script A)

1. a) How can you tell whether a machine or program is intelligent? (10) [CO1]  
 b) Describe the Wumpus world characterization briefly. (10) [CO2]  
 c) “The plant is tree; If the plant is a tree, then it has a trunk; If the plant has a trunk and produces fruit, then it is a fruit tree; If the plant has a trunk and produces flowers and not fruit, then it is a flowering tree; If the plant is a fruit tree and produces apples, then it is an apple tree; If the plant is a fruit tree and produces oranges, then it is an orange tree; If the plant is a flowering tree and has pink flowers, then it is a cherry blossom tree; If the plant is a flowering tree and has white flowers, then it is a magnolia tree; The plant produces flowers; The plant has pink flowers.” (15) [CO4]  
 From the above information, is it possible to prove “The plant is a cherry blossom tree”? If yes, then do it, otherwise ignore.

2. a) Identify the valid and satisfiable sentences from the following sentences and justify your logic behind your identification. (10) [CO1]  
 i)  $(p \rightarrow q) \wedge (\neg q \rightarrow \neg p)$ .  
 ii)  $(p \wedge q) \rightarrow p$ .  
 b) Consider the Wumpus world problem. The  $A, W, S, B, G$  and  $P$  in the grid define the facts of the Wumpus world. (15) [CO3]

$S$		$B$	$P$
	$S$		
$W$	$B$	$P$	$B$
	$G$		
$S$		$B$	
$A$	$B$	$P$	$B$

Derive some rules from the Wumpus world problem using the above grid and show that there is a Pit ( $P_{3,3}$ ) in the (3,3) position.

- c) Among the propositional logic and predicate logic, which one will you choose for knowledge representation and why? (10) [CO1]
3. a) Find out the objects, relations, properties and functions from the following sentences. (12) [CO2]  
 i) The cat chases the mouse.  
 ii) The sun rises in the east.  
 iii) Socrates is a philosopher.  
 iv) The book is on the table.  
 b) “According to the company policy, it is considered intrusion if any employee accesses confidential files without clearance. Tom accessed confidential files and Tom does not have clearance.” (13) [CO3]  
 Using the forward chaining of first-order logic, prove that Tom is an intruder.  
 c) What is alpha-beta pruning? Why do you need it in game theory? Explain your answer with proper example. (10) [CO3]
4. a) Discuss the concept of bidirectional search. How does it improve search efficiency? What are the challenges associated with implementing bidirectional search? (10) [CO3]  
 b) Define action in planning. Why do we study planning in artificial intelligence (AI)? (10) [CO1]

- c) Consider planning problem in the block's world where a robot with one hand wants to rearrange the following blocks from the initial state to the goal state. Now, design exactly two actions and show the sequence of actions should perform by the robot to achieve the job done by forward planning. (15) [CO2]

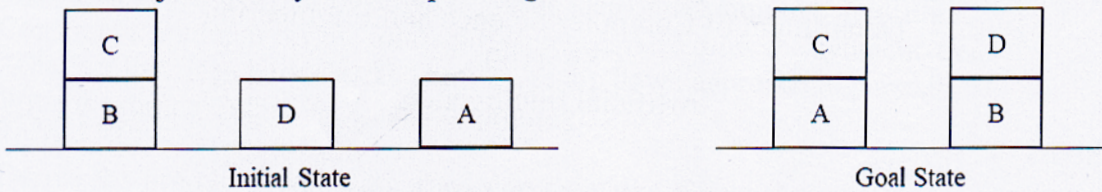

### SECTION B

(Answer ANY THREE questions from this section in Script B)

5. a) What is AI? To what extent are the following computer systems instances of AI? (12) [CO2]  
Explain.
- i) Supermarket barcode scanners.
  - ii) Voice-activated telephone menus.
  - iii) Internet routing algorithms.
- b) Consider a rabbit grazing in a carrot field. What are its sensors, actuators, and environment? Discuss how its sensors and actuators are well-suited to its environment? (13) [CO3]
- c) Give a demystified classification of AI. "The most subfield in AI focuses on smaller components thought to be necessary for producing intelligent programs" – justify the statement. (10) [CO2]
6. a) A doctor knows that the disease meningitis causes the patient to have stiff neck 70% of the time. The prior probability that a patient has meningitis is 1/50,000 and for stiff neck is 1%. Calculate,  $p(\text{meningitis}|\text{stiffneck})$ . (13) [CO2]
- b) Define PEAS for each of the following activities, give a PEAS description of the task environment. (12) [CO4]
- i) Knitting a sweater.
  - ii) Playing soccer.
- c) What is the significance of Turing test in AI? Explain briefly. (10) [CO1]
7. a) What is uncertainty? Explain different types of uncertainty using example(s). (10) [CO2]
- b) Derive the product formula for Bayesian network. Show the steps to calculate the product formula of the following Bayesian network. (13) [CO4]

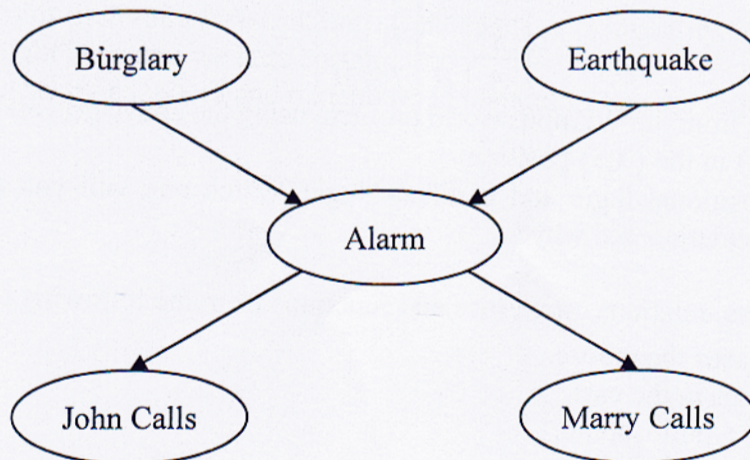

- c) Formulate graph coloring problem as constraint satisfaction problem. Draw the constraint graph for an arbitrary graph. (12) [CO2]
8. a) What do you mean by fuzzy logic system? Explain using example. (10) [CO1]
- b) Explain different operations on fuzzy sets. Use pictorial representation for their clarification. (10) [CO2]
- c) Design a fuzzy logic based Air-conditioning system for your classroom using fuzzy expert system development methodology. (15) [CO3]

KHULNA UNIVERSITY OF ENGINEERING & TECHNOLOGY  
 B.Sc. Engineering 4<sup>th</sup> Year 1<sup>st</sup> Term Examination, 2023  
 Department of Computer Science and Engineering  
 CSE 4111  
 Machine Learning

TIME: 3 hours

FULL MARKS: 210

- N.B. i) Answer **ANY THREE** questions from each section in separate scripts.  
 ii) Figures in the immediate right column of the questions indicate full marks.  
 iii) The rightmost column indicates course outcomes.

**SECTION A**

(Answer **ANY THREE** questions from this section in Script A)

1. a) Define machine learning and discuss its different types. (06) [CO1]  
 b) Derive the Lagrangian dual objective function and formulate the equations that uniquely characterize the solution to both the primal and dual problems for the Support Vector Machine (SVM). (14) [CO3]  
 c) Explain how Directed Acyclic Graph (DAG) SVM addresses the drawback of the 1-vs-1 SVM approach, where the number of SVMs increases super-linearly with number of classes, in data classification. (08) [CO2]  
 d) Discuss the relationship between Gini Impurity and Information Gain. (07) [CO2]
  
2. a) How does a separating hyperplane that perfectly classifies all of the training observations lead to sensitivity to individual observations? Explain in detail. (10) [CO2]  
 b) Can SVM be over trained? What can be the effect of over training? How can over-fitting be detected for a SVM model? (07) [CO2]  
 c) Consider the following two hyperplanes: (08) [CO3]  
      $5 + 2x_1 + 5x_2$  (for classifier 1)  
      $5 + 20x_1 + 50x_2$  (for classifier 2)  
 Compute the distance error function and identify which classifier built with these hyperplanes will have better performance.  
 d) 'The maximal margin hyperplane for SVM depends directly on only a small subset of the observation' – justify the statement. (10) [CO1]
  
3. a) Explain Occam's razor principle. In the context of decision tree learning, when we prioritize simplicity over complexity, do you believe Occam's razor adequately justifies the algorithm's inclination toward simpler hypotheses? (10) [CO1]  
 b) Discuss the impact of outliers on the performance of a maximum margin classifier. How can the classifier be sensitive to outliers and what techniques can be employed to address this issue? (12) [CO2]  
 c) Consider the following table where attribute 'Status' represents class label. Find the root attribute of the decision tree using Gain Ratio as the attribute selection measure. (13) [CO3]

Department	Age	Status	Salary
Sales	31–35	Senior	Medium
Sales	26–30	Junior	Low
Marketing	36–50	Senior	High
Secretary	26–30	Senior	Medium
Secretary	36–50	Senior	High
Sales	36–50	Junior	High
Marketing	31–35	Senior	Medium
Marketing	26–30	Junior	Low
Secretary	31–35	Junior	Medium
Secretary	26–30	Junior	Low

4. a) Discuss the empty space phenomenon and demonstrate the working principle of kernel Principle Component Analysis (PCA) in dimensionality reduction for linearly inseparable input data. Under what conditions does kernel PCA function similarly to standard PCA? (11) [CO1]  
 b) What is inductive bias in decision tree learning and which type of inductive bias is used in BFS-ID3 algorithm? Illustrate how BFS-ID3 algorithm exhibits the bias 'shorter trees are preferred over longer trees' with detailed explanation. (12) [CO2]

c) Consider the following training data:

(12) [CO1]

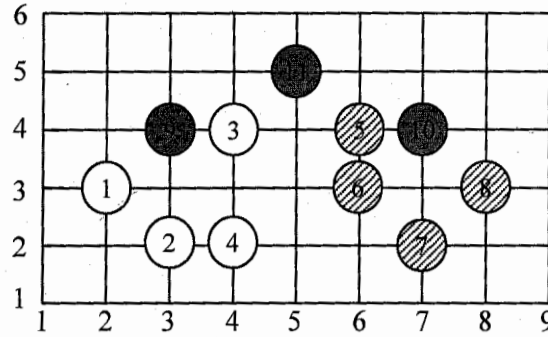

Let  $y_A = -1, y_B = +1$  be the class indicators for both classes where

$$A = \{(1), (2), (3), (4)\} \text{ and } B = \{(5), (6), (7), (8)\}$$

- Just using the above standing plot, specify which of the points should be identified as support vectors.
- Draw the maximum margin line which separates the classes (you don't have to do any computations here). Write down the normalized normal vector  $w \in \mathbb{R}^2$  of the separating line and the offset parameter  $b \in \mathbb{R}$ .
- Consider the decision rule:  $H(x) = \langle w, x \rangle + b$ . Now determine the class for the points .

### SECTION B

(Answer ANY THREE questions from this section in Script B)

- Suppose, we want to fit a line  $y = mx + b$  through the points (1, 2), (2, 3), (3, 4), (4, 5) and (5, 6). Assume, initial values of  $m$  and  $b$  are 0.1 and 0.2 respectively. Calculate the initial error using mean squared error loss function and then apply a gradient descent step. Use learning rate,  $\alpha = 0.01$  and calculate the error of fit again after the gradient descent step. (12) [CO3]
  - Demonstrate automatic differentiation (AD) using a suitable example. How does AD differ from numerical differentiation? (07) [CO1]
  - Explain why Convolutional Neural Network is preferred over Multi-Layer Perceptron for image related tasks. (04) [CO2]
  - Explain how artificial neural networks can be used to solve following problems. (12) [CO4]
    - Duplicate/ near duplicate image identification.
    - Anomaly detection.
    - Dimensionality reduction.
- Briefly explain the idea of transfer learning. (05) [CO1]
  - What is exploration and exploitation in swarm intelligence algorithms? Explain how these features are provided in following algorithms. (16) [CO1]
    - Genetic algorithm (GA).
    - Particle swarm optimization (PSO).
    - Ant colony optimization (ACO).
    - Artificial bee colony (ABC).
  - What are the disadvantages of Roulette Wheel selection? (03) [CO2]
  - Create a child using Cycle crossover and another child using Enhanced Edge Recombination for the following parents. (11) [CO3]

Parent 1

1	2	3	4	5	6
---	---	---	---	---	---

Parent 2

5	6	1	3	4	2
---	---	---	---	---	---
- "PSO cannot be used for discrete optimization problem" – justify this statement. (05) [CO1]
  - Perform one iteration of PSO to minimize the function  $f(x, y) = (x - 2)^2 + (y - 3)^2$  in the range  $-10 \leq x, y \leq 10$ . Parameters and initial values are given below where the symbols have their usual meanings. (10) [CO3]

Parameters:  
 $N = 2, \omega = 0.5,$   
 $C_1 = 1.5, C_2 = 1.5$   
 $r_1 = 0.3, r_2 = 0.7$

Initial values:  
 Particle 1: Position  $(x_1, y_1) = (5, 5),$   
 Velocity  $(v_{1x}, v_{1y}) = (0.1, 0.1).$   
 Particle 2: Position  $(x_2, y_2) = (3, 1),$   
 Velocity  $(v_{2x}, v_{2y}) = (0.2, 0.2).$
- Write down the equations of transition probability and pheromone update of ACO. Also, describe the effects of key parameters. (10) [CO1]
  - Explain the employee bee phase, on looker bee phase and scout bee phase in ABC optimization algorithm. (10) [CO1]

8. a) Explain how clustering can be used for image color quantization. (04) [CO3]  
b) Explain how to calculate and interpret Silhouette score. (06) [CO2]  
c) What is the problem of random centroid initialization in case of  $k$ -means clustering? (11) [CO2]  
Explain how  $k$ -means++ or GA can be used to solve this problem (explain both approaches).  
d) Using agglomerative hierarchical clustering create a dendrogram for the data shown in (14) [CO3]  
following table.

Student ID	Marks
1	15
2	12
3	33
4	25
5	40

KHULNA UNIVERSITY OF ENGINEERING & TECHNOLOGY  
B.Sc. Engineering 4<sup>th</sup> Year 1<sup>st</sup> Term Examination, 2023  
Department of Computer Science and Engineering  
CSE 4115

Computer and Network Security

TIME: 3 hours

FULL MARKS: 210

- N.B. i) Answer **ANY THREE** questions from each section in separate scripts.  
ii) Figures in the immediate right column of the questions indicate full marks.  
iii) The rightmost column indicates course outcomes.

**SECTION A**

(Answer **ANY THREE** questions from this section in Script A)

1. a) Define and discuss goals of computer security. Using a block diagram show relation (08) [CO1] and explain terminologies of any cryptosystem.  
b) Discuss Shannon characteristics to describe characteristics of good cipher. “Ciphertext size should not be larger than plaintext” – show how RSA and ElGamal cryptosystems retain this criterion. (14) [CO2]  
c) Define and discuss characteristics of zero-knowledge proof. How and why digital signatures with public key cryptography is required to combine? Explain the procedure. (13) [CO2]
2. a) Using block diagrams show that asymmetric cryptosystem is alluring than symmetric cryptosystem. Illustrate the major steps of each cycle of AES algorithm using an appropriate diagram. (13) [CO1]  
b) Discuss characteristics of cryptographic hash function. Asymmetric cryptosystem and hash technique need to combine concurrently – why and how? (13) [CO1]  
c) Various malicious codes have different characteristics – discuss them briefly. Explain characteristics of good viruses. (09) [CO2]
3. a) Discuss properties retained by digital signatures (DS). Derive the steps of ElGamal digital signature. Show that it is capable to satisfy properties of DS. (13) [CO3]  
b) Define the term cryptanalysis. Explain three terms allied with attack on cryptanalysis. (10) [CO1]  
c) Explain the working procedure of Double DES and Triple DES. Establish a comparative analysis between AES and DES based on various features of design. (12) [CO2]
4. a) ElGamal cipher can be developed to form ‘product cipher’ and ‘re-randomized cipher’. How? Show step by step. (14) [CO4]  
b) Derive encryption-decryption procedure of Caesar cipher and Vernam cipher. For RSA algorithm from  $ed \equiv 1 \pmod{\phi(n)}$ , establish that many values may exist for  $d$  for a single value of  $e$ , where symbols have their usual meanings. (14) [CO3]  
c) Derive a bonding among order, prime and primitive element considering the prime 13 and order 2. (07) [CO4]

**SECTION B**

(Answer **ANY THREE** questions from this section in Script B)

5. a) What are covert channels? Differentiate between error and fault. (08) [CO2]  
b) What is ‘Salt’ in rainbow table attack? How does viruses gain control in file directory? (10) [CO1]  
c) What is segmentation fault in buffer overflow attack? Explain with figure. Also, discuss the countermeasures of buffer overflow attack. (10) [CO2]  
d) How webcams are used in Distributed Denial of Service (DDOS) attack? (07) [CO3]
6. a) Explain how paging removes the drawbacks of segmentation. (08) [CO3]  
b) Show how integer overflow attack compromises a program’s reliability and security. (15) [CO4]  
c) How does a Demilitarized Zone (DMZ) network work? “Paillier cryptosystem permits addition of two ciphertexts, or one ciphertext and one plaintext or multiplication of one ciphertext and one plaintext” – justify it. (12) [CO4]
7. a) “Format string vulnerability is responsible to crash a program” – explain it. (05) [CO2]  
b) Explain relocation with example. What are the advantages of segmentation in operating system? (10) [CO2]  
c) Write short notes on the followings: (12) [CO1]  
(i) Trojan horse, (ii) Boot sector viruses, (iii) Dictionary attack.  
d) What is macro? Discuss how does document virus attack work in excel file using Dynamic Data Exchange (DDE). (08) [CO4]

8. a) What is a virus signature? How does antivirus work on a system? (10) [CO2]  
b) Differentiate between Intrusion Detection Systems (IDS) and Intrusion Prevention Systems (IPS). (10) [CO2]  
c) What is light weight cryptography? Give an example and working procedure of it. (10) [CO4]  
d) Describe Stateful Inspection firewalls. (05) [CO1]

KHULNA UNIVERSITY OF ENGINEERING & TECHNOLOGY  
 B.Sc. Engineering 4<sup>th</sup> Year 1<sup>st</sup> Term Examination, 2023  
 Department of Computer Science and Engineering  
 CSE 4127

Image Processing and Computer Vision

TIME: 3 hours

FULL MARKS: 210

- N.B. i) Answer **ANY THREE** questions from each section in separate scripts.  
 ii) Figures in the immediate right column of the questions indicate full marks.  
 iii) The rightmost column indicates the course outcomes.

**SECTION A**

(Answer **ANY THREE** questions from this section in Script A)

1. a) For the following two signals  $f(x)$  and  $g(x)$ , find  $f(x) * g(x)$ , where  $*$  is a (07) [CO1] convolution operator.

$$f(x) = \begin{cases} 1 & 0 \leq x \leq 1 \\ 0 & \text{otherwise} \end{cases} \quad g(x) = \begin{cases} 1/2 & 0 \leq x \leq 1 \\ 0 & \text{otherwise} \end{cases}$$

- b) You are assigned to smooth the following image while preserving the edges. You (16) [CO2] planned to use a bilateral filter of size  $3 \times 3$ , and Gaussian function for both spatial kernel and range kernel. If you use  $\sigma_s = 0.6$ , and  $\sigma_r = 15$  for those kernels, then show the spatial, range, and bilateral kernel for the encircled position of the following image.

$$\begin{bmatrix} 10 & 12 & 76 & 70 \\ 6 & \textcircled{5} & 66 & 68 \\ 4 & 25 & 55 & 62 \\ 8 & 9 & 71 & 58 \end{bmatrix}$$

- c) For the given filter, determine the DTFT  $H(u, v)$  of the filter (assuming the origin is at (12) [CO3] the center), and sketch the one-dimension profiles  $H(u, 0)$  and  $H(0, v)$ .

$$\begin{bmatrix} -1 & -3 & -1 \\ 0 & 0 & 0 \\ 1 & 3 & 1 \end{bmatrix}$$

2. a) Show that Laplacian sharpening is a special case of an Un-Sharp Mask (USM) filter. (07) [CO3]  
 b) Use required mathematical formulation to show that the between class variance used (14) [CO1] by Otsu's thresholding method can be written as

$$\sigma_B^2(k) = \frac{(m_G P_1(k) - m(k))^2}{P_1(k)(1 - P_1(k))}$$

- c) Estimate the optical flow for the following successive video frames using Lucas– (14) [CO2] Kanade method. Use masks suggested by Horn-Schunck to compute necessary partial derivatives. Also use a  $2 \times 2$  spatial coherence window, and show the estimated result for encircled position only.

$$\begin{bmatrix} 1 & 0 & 1 & 1 \\ 2 & \textcircled{9} & 9 & 8 \\ 1 & 9 & 9 & 10 \\ 0 & 9 & 8 & 9 \end{bmatrix}$$

Frame at  $t$

$$\begin{bmatrix} 1 & 1 & 0 & 1 \\ 1 & 1 & 0 & 1 \\ 0 & 2 & 10 & 9 \\ 1 & 1 & 9 & 8 \end{bmatrix}$$

Frame at  $t + 1$

3. a) Geometric transformation of the following image is done by an inverse polynomial (13) [CO3] mapping function such as:  $Y = WP(X)$ , where,

$$X = [x_1 \quad x_2]^T, Y = [y_1 \quad y_2]^T,$$

$$P(x) = [1 \quad x_1 \quad x_2 \quad x_1^2 \quad x_1 x_2 \quad x_2^2], \text{ and}$$

$$W = \begin{bmatrix} 0.1 & 1 & 0 & 0.01 & -0.01 & 0.01 \\ 0.4 & 0 & 1 & 0.02 & -0.01 & 0.04 \end{bmatrix}$$

Determine output intensity at (1, 2), if bilinear interpolation is used during transformation.

$$\begin{array}{c} \downarrow x_2 \\ \begin{array}{c} 0 \\ 1 \\ 2 \\ 3 \\ 4 \end{array} \begin{array}{c} \longrightarrow x_1 \\ \begin{bmatrix} 100 & 105 & 108 & 109 & 102 \\ 99 & 104 & 109 & 100 & 103 \\ 200 & 204 & 205 & 102 & 105 \\ 201 & 106 & 101 & 103 & 111 \\ 206 & 208 & 204 & 200 & 100 \end{bmatrix} \end{array} \end{array}$$

- b) Let two interest points are described by some feature descriptors. Provide at least two matching ideas, with necessary equations, that can be used to decide whether those interest points are same or not. Also mention the pros and cons of those matching ideas. (12) [CO4]
- c) Write Niblack's adaptive thresholding algorithm. Mention its use-cases. (10) [CO1]
4. a) During Hough transform based line detection, generally we get similar vote count in a small neighborhood. Explain what strategy can be applied to locate the peak voting position in the accumulator array. (06) [CO4]
- b) Apply a  $3 \times 3$  vector median filter on the location (2, 2) of the given RGB image. (13) [CO2]

	0	1	2	3
0	1	0	2	1
1	3	2	1	2
2	3	0	2	4
3	2	1	0	1

R

	0	1	2	3
0	2	1	2	1
1	1	3	1	0
2	3	0	2	2
3	1	2	2	3

G

	0	1	2	3
0	3	3	1	2
1	2	3	0	1
2	1	0	2	1
3	3	1	2	2

B

- c) Use DiZenko-Cumani operator to get the edge strength and orientation for the following color image: values inside the parenthesis means (r,g,b) color vector. Also mention the importance of the operator compared to monochromatic edge detection technique for color image. Show result only for the center pixel. (16) [CO3]

(3, 2, 1)	(2, 1, 2)	(2, 3, 0)
(1, 3, 1)	(3, 0, 1)	(2, 2, 3)
(1, 1, 0)	(0, 2, 4)	(1, 1, 1)

### SECTION B

(Answer ANY THREE questions from this section in Script B)

5. a) Define digital image processing. Briefly discuss the fundamental steps in digital image processing. (10) [CO1]
- b) Consider the image segment shown below. (12) [CO2]

		3	1	2	1	← q
		2	2	0	2	
		1	2	1	1	
p →		1	0	1	2	

Compute length of the shortest-4, shortest-8 and shortest- $m$  paths between pixels  $p$  and  $q$  where,  $v = \{1, 2\}$ . If a particular path does not exist between these two points, explain why.

- c) Consider the following 3-bit image. (13) [CO3]
- i) Generate the equalized image by using global histogram equalization processing.
  - ii) Plot the histogram of the processed image.

2	3	3	5	7
5	4	3	1	6
1	5	2	4	7
2	3	6	4	1
6	5	3	2	4

6. a) Define morphological gradient. Discuss when do we use top-hat and bottom-hat transformation in grayscale image. (10) [CO2]
- b) Let, you are asked to enhance dark areas of an image while leaving the bright area as unchanged as possible. Propose strategy with necessary formulation to handle the problem. Use example to explain that the proposed method works. (14) [CO3]
- c) Briefly discuss the following morphological image processing operations with necessary equations. (11) [CO3]
- i) Convex hull.
  - ii) Pruning.

7. a) Perform grayscale morphological opening operation on the given image below. Use (10) [CO4] supplied non-flat structuring element. Show result only for the middle row.

50	55	49	42	43
43	40	48	45	44
42	48	52	46	43
51	53	47	49	45
48	50	49	51	48

Image

Center →	③	4	1
	2	5	2
	6	4	7

Structuring Element

- b) Briefly explain how 'golomb coding' can be used in image compression. Compute (13) [CO2]  $G_4(9)$  and  $G_{exp}^0$ .
- c) Discuss the necessary steps involved in JPEG image compression. Use example to (12) [CO1] explain.
8. a) Develop the mathematical model for the degradation due to uniform linear motion. (12) [CO4]
- b) Consider the following image. Now apply  $3 \times 3$  alpha-trimmed mean filter with  $d = 4$  (08) [CO2] to remove noises from it.

3	4	5	4	3
2	10	4	5	1
0	5	6	2	0
1	6	3	0	5
0	15	3	3	2

- c) A degraded image is represented by  $G(u, v)$  in the frequency domain and an estimation (15) [CO2] of its degradation function is

$$H(u, v) = -\sigma \sqrt{2\pi} (u^2 + v^2) e^{-j2\pi^2 \sigma^2 (u^2 + v^2)}$$

Provide the expression in the frequency domain of the restored image using the Wiener filter. Assume that the power spectrum of the undegraded image is ten times the power spectrum of the noise throughout the image.

KHULNA UNIVERSITY OF ENGINEERING & TECHNOLOGY  
B.Sc. Engineering 4<sup>th</sup> Year 1<sup>st</sup> Term Examination, 2023  
Department of Computer Science and Engineering  
IEM 4127  
Industrial Management

TIME: 3 hours

FULL MARKS: 210

- N.B. i) Answer **ANY THREE** questions from each section in separate scripts.  
ii) Figures in the immediate right column of the questions indicate full marks.  
iii) The rightmost column indicates the course outcomes.

**SECTION A**

(Answer **ANY THREE** questions from this section in Script A)

1. a) Analyze how the structure of line, line and shaft and functional organizations impact decision making processes within business. Compare their effects. (13) [CO1]  
b) What recommendations can be proposed for ensuring the efficient functioning of a committee within an organization? (10) [CO2]  
c) Describe the key managerial skills that contribute to effective leadership within organizations. (12) [CO2]
2. a) Explain the common obstacles to effective delegation. (10) [CO2]  
b) Demonstrate how the environment makes management a dynamic process and illustrate your explanation with a proper figure. (13) [CO4]  
c) Explain Herzberg's theory of motivation. How does it differ from Maslow's theory? Also, outline its limitations. (12) [CO3]
3. a) In a software development startup, CEO Alen aimed to adopt a leadership approach where employees, particularly experienced developers, were given the freedom to make decisions independently. What leadership style was implemented in the startup, and how does it influence the performance of teams? (12) [CO3]  
b) Explain how the systems theory school views an organization as a system. (11) [CO2]  
c) A job is rated in terms of wages of TK. 800 per day. The standard time set for the job is 10 days, 8 hours/day. Two workers have taken 75 and 85 hours respectively for the completion of the job. A bonus of 70% on the time taken will be given only to those who have completed the job in the standard time. Calculate the earnings of each individual by Bedaux plan. Here, 1B stands for 0.8 standard work minute and it includes working time as well as time for rest. (12) [CO4]
4. a) Define upper and lower breakeven point. Why breakeven analysis is called short-run analysis? (10) [CO2]  
b) Handheld optic meters are useful for measuring temperature, pressure and strain. The fixed costs associated with manufacturing are \$800,000 per year. If a base unit sells (revenue) for \$2,850 and its variable cost is \$1,975. (13) [CO4]  
i) How many units must be sold each year for breakeven?  
ii) What will be the profit for a sale of 3,500 units per year?  
c) A gas processor has fixed cost of \$30,000 with a \$6,000 salvage value after 6 years. Find the (12) [CO4]  
i) Depreciation  $D_3$  and,  
ii) Book value after 3 years using SL depreciation.

**SECTION B**

(Answer **ANY THREE** questions from this section in Script B)

5. a) Explain the trade-off between responsiveness and stability in a forecasting system that uses time-series data. (10) [CO4]  
b) What are some of the consequences of poor forecasts? Explain. (10) [CO1]  
c) The manager of 'Rokomari' bookstore believes that the annual sales volume of pocket calculators is strongly related to the number of new students enrolled in the schools of engineering and business administration. Data collected over the last several years on relevant new student enrollments and calculator sales are shown in Table 5(c). (15) [CO4]  
i) Plot the points corresponding to calculator sales Y for the given enrollment levels X.  
ii) Find the least-squares regression line.

- iii) How many calculators should the bookstore expect to sell in 1981 if the anticipated enrollment of new engineering and business administration students is 2,500?

Table 5(c)

Year	New student enrollment in engineering and business administration	Pocket calculator sales
1971	1,000	290
1972	700	280
1973	300	140
1974	600	220
1975	1,200	400
1976	700	330
1977	500	210
1978	1,000	390
1979	800	280
1980	500	200

6. a) The administrative services of a government agency require 2,400 rolls of duplicating paper per year for copiers. Holding costs are estimated to be \$3.60 per roll per year, and the cost of replenishment for the item is equal to \$25 per order. (15) [CO4]
- Prepare a table showing the average inventory, number of orders holding cost, and ordering cost for order quantities in multiples of 200 rolls.
  - Plot the relevant cost curves for each order-quantity value.
  - Identify on the table the minimum-cost order quantity and compare this with the EOQ from the graph of part (ii).
- b) What is a safety stock? Analyze why it might be inappropriate to use inventory turnover ratios to compare inventory performance of companies that are in different industries. (10) [CO2]
- c) Show the contributions of MRP to enhance productivity. Also, contrast planned-order receipts and scheduled receipts. (10) [CO1]
7. a) What are Gantt charts? How are they used in scheduling? (9) [CO4]
- b) A group of five jobs is to be processed through a two-machine flow shop. The first operation involves cleaning and the second involves painting. Determine a sequence that will second involves painting. Determine a sequence that will minimize the total completion time for this group of jobs. Processing time are as follows. (12) [CO2]

Job times (hours)

Job	Work Center A	Work center B
a	2.50	4.20
b	3.80	1.50
c	2.20	3.00
d	5.80	4.00
e	4.50	2.00

- c) A table is assembled using three components as shown in the following product structure tree. The company that makes the table wants to ship 100 units at the beginning of day 4, 150 units at the beginning of day 5, and 200 units at the beginning of day 7. Receipts of 100 wood sections are scheduled at the beginning of day 2. There are 120 legs on hand. An additional 10 percent of the order size on legs is added for safety stock. There are 60 braces on hand with no safety stock requirement for braces. Lead times (in days) for all items are shown in following table. Prepare a MRP using lot-for-lot ordering. (14) [CO4]

Table

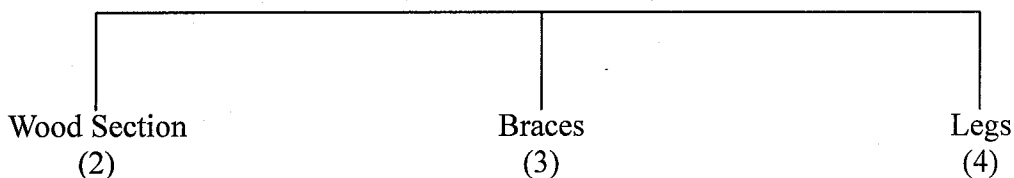

Quantity	Lead Time
1-200	1
201-550	2
551-999	3

8. a) Deduce the EOQ model with assumptions. Also, discuss the difference between EOQ and EPQ model. (10) [CO3]
- b) AlumCo Ltd. Plans to set up a new aluminum-products plant and has selected three sites (15) [CO3] with the following characteristics (For projected 75 percent utilization equal to 300,000 tons/year):

Site	Annual Fixed Costs (millions)	Variable costs/ton
A	8.2	\$452
B	10	\$290
C	7.5	\$530

Relevant Subjective Factors	Rating $R_{ij}$			Relative importance Index $w_j$
	A	B	C	
Housing	0.25	0.50	0.25	0.50
Community attitudes	0.25	0.25	0.50	0.25
Services	0.50	0.25	0.25	0.25

Determine the optimum location site if objective factors weigh twice as much as subjective factors.

- c) Write short notes on (i) MRP, (ii) ROP, (iii) Inventory records, and (iv) Bill of materials. (10) [CO2]